

**User Manual of
Portable Air-conditioners
Professional**



Please read this user's manual carefully to ensure proper use, maintenance and installation

Ecofer K. Z. OIKONOMOU

Ithomis Str. 6, Chalandri, GR-15231

Athens - Greece

Tel: +30210 6715510 / +30211 7007269/ +30211 7007270

Fax: +302106542877

Website: www.ecofer.com.gr

Table of contents

Safety instructions.....	1
Name of parts	4
Accessories.....	4
Appearance and function of control panel	5
Appearance and function of remote controller	5
Operation introduction	6
Installations explanations.....	9
Maintenance explanations.....	10
Troubleshooting	11
Recycling	12
Guarantee	12

Safety instructions

VERY IMPORTANT!

Please do not install or use your mobile air conditioner before you have carefully read this manual. Please keep this instruction manual for an eventual product warranty and for future reference.

1. The appliance is for indoor use only.
2. Do not use the unit on a socket under repairs or not installed properly
3. Do not use the unit, follow these precautions:
 - A: Near to source of fire.
 - B: An area where oil is likely to splash.
 - C: An area exposed to direct sunlight.
 - D: An area where water is likely to splash.
 - E: Near a bath, a laundry, a shower or a swimming pool.
4. Never insert your fingers, rods into the air outlet. Take special care to warn children of these dangers.
5. Keep the unit upward while transport and storage, for the compressor locates properly.
6. Before cleaning the air-conditioner, always turn off or disconnect the power supply.
7. When moving the air-conditioner, always turn off and disconnect the power supply, and move it slowly.
8. To avoid the possibility of fire disaster, the air-conditioner shall not be covered.
9. All the air-conditioner sockets must comply with the local electric safety requirements. If necessary, please check it for the requirements.
10. Children should be supervised to ensure that they do not play with the appliance.
11. If the supply cord is damaged, it must be replaced by the manufacturer, its service agent or similarly qualified persons in order to avoid a hazard.
12. This appliance can be used by children aged from 8 years and above and persons with reduced physical, sensory or mental capabilities or lack of experience and knowledge if they have been given supervision or instruction concerning use of the appliance in a safe way and understand the hazards involved. Children shall not play with the appliance. Cleaning and user maintenance shall not be made by children without supervision.
13. The appliance shall be installed in accordance with national wiring regulations.
14. Details of type and rating of fuses: T, 250V AC,2A.
15. Contact authorized service technician for repair or maintenance of this unit.
16. Do not pull, deform. or modify the power supply cord, or immerse it in water. Pulling or misuse of the power supply cord can result in damage to the unit and cause electrical shock.
17. Compliance with national gas regulations shall be observed.
18. Keep ventilation openings clear of obstruction.
19. Any person who is involved with working on or breaking into a refrigerant circuit should hold a current valid certificate from an industry-accredited assessment authority, which authorizes their competence to handle refrigerants safely in accordance with an industry recognized assessment specification.
20. Servicing shall only be performed as recommended by the equipment manufacturer. Maintenance and repair requiring the assistance of other skilled personnel shall be carried out under the supervision of the person competent in the use of flammable refrigerants.
21. Do not operate or stop the unit by inserting or pulling out Die power plug, it may cause electric shock or fire due

to heat generation.

22. Unplug the unit if strange sounds, smell, or smoke comes from it.

Warning

- Do not use means to accelerate the defrosting process or to clean, other than those recommended by the manufacturer.
- The appliance shall be stored in a room without continuously operating ignition sources (for example: open flames, an operating gas appliance or an operating electric heater).
- Do not pierce or burn.
- Be aware the refrigerants may not contain an odor.
- Appliance shall be installed, operated and stored in a room with a floor area larger than 15 m².

• **Notes:**

- If any parts damage, please contact the dealer or a designated repair shop.
- In case of any damage, please turn off the air switch, disconnect the power supply, and contact the dealer or a designated repair shop.
- In any case, the power cord shall be firmly grounded.
- To avoid the possibility of danger, if power cord is damaged, please turn off the air switch and disconnect the power supply. It must be replaced from the dealer or a designated repair shop.

Specific information regarding appliances with R 290 refrigerant gas:

- Thoroughly read all of the warnings.
- When defrosting and cleaning the appliance, do not use any tools other than those recommended by the manufacturing company.
- The appliance must be placed in an area without any continuously sources of ignition (for example: open flames, gas or electrical appliances in operation).
- Do not puncture and do not burn.
- This appliance contains Y g (see rating label back of unit) of R290 refrigerant gas.
- R290 is a refrigerant gas that complies with the European directives on the environment. Do not puncture any part of the refrigerant circuit.
- If the appliance is installed, operated or stored in a nonventilated area, the room must be designed to prevent to the accumulation of refrigerant leaks resulting in a risk of fire or explosion due to ignition of the refrigerant caused by electric heaters, stoves, or other sources of ignition.
- The appliance must be stored in such a way as to prevent mechanical failure.
- Individuals who operate or work on the refrigerant circuit must have the appropriate certification issued by an accredited organization that ensures competence in handling refrigerants according to a specific evaluation recognized by associations in the industry.
- Repairs must be performed based on the recommendation from the manufacturing company. Maintenance and repairs that require the assistance of other qualified personnel must be performed under the supervision of an individual specified in the use of flammable refrigerants.

REFRIGERANT





(CE) N 842/2006: This air conditioner contains the refrigerant R290. The amount of refrigerant is less than 1kg, and is in a closed cooling circuit. The coolant does have zero ozone depletion potential, but is a so-called greenhouse gas under the Kyoto Protocol and may thus contribute to global warming, if it is released to the atmosphere. Therefore, only trained technicians with refrigerant certificate make a filling or emptying. Your air conditioner does not have to be refilled with refrigerant if used properly and has an undamaged coolant circuit. GWP: R290: 3

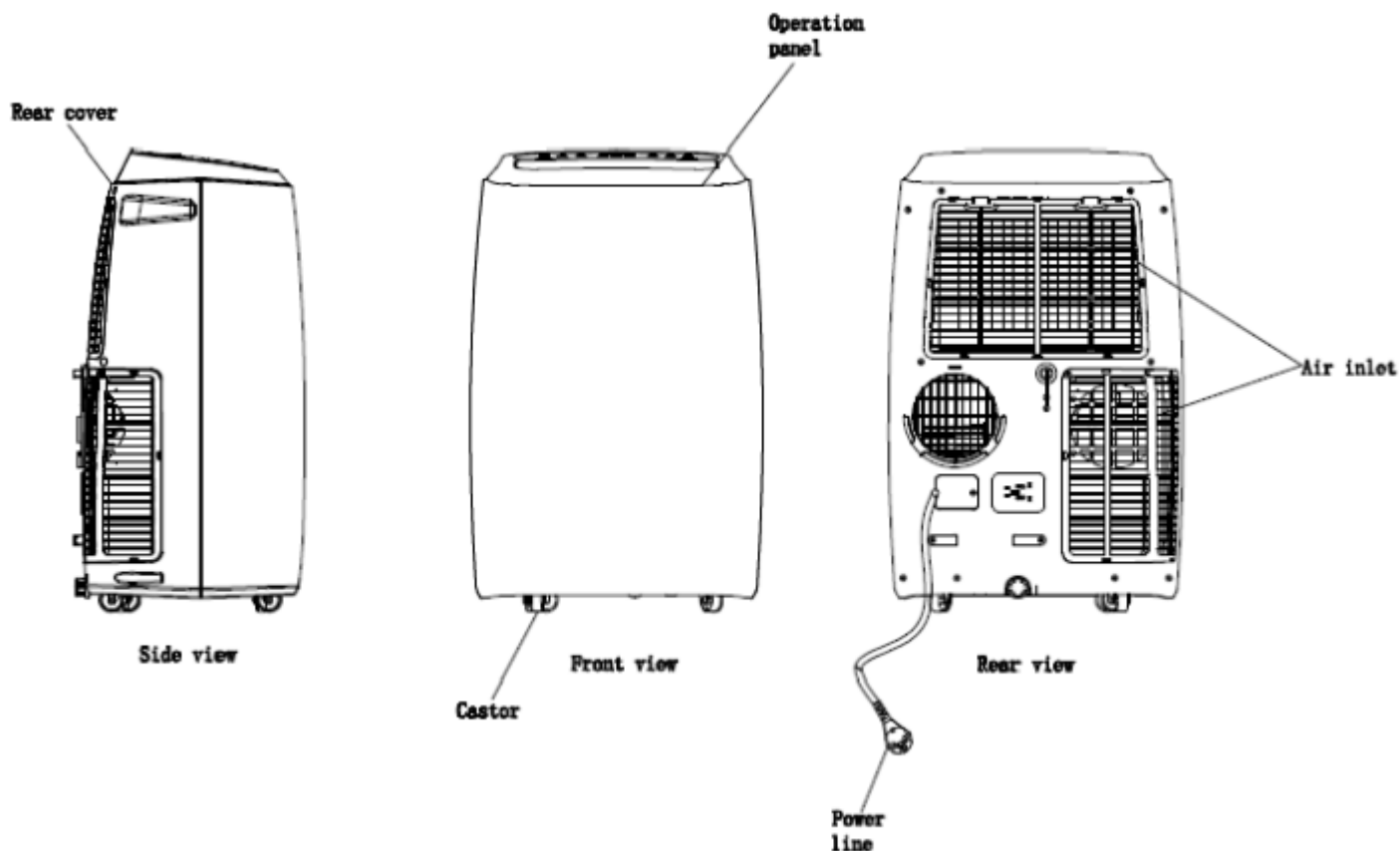

Name of parts



Accessories

Part	Description	Quantity
	Main Air Conditioner Unit	1
	Hot-Air exhaust hose	1
	Hose Connector (Window end)	1
	Hose Connector (Air Conditioner end)	1
	Remoter Controller	1

After unpacking, please check whether the above-mentioned accessories are included, and check their purposes in the installation introduction in this manual.

Appearance and function of control panel

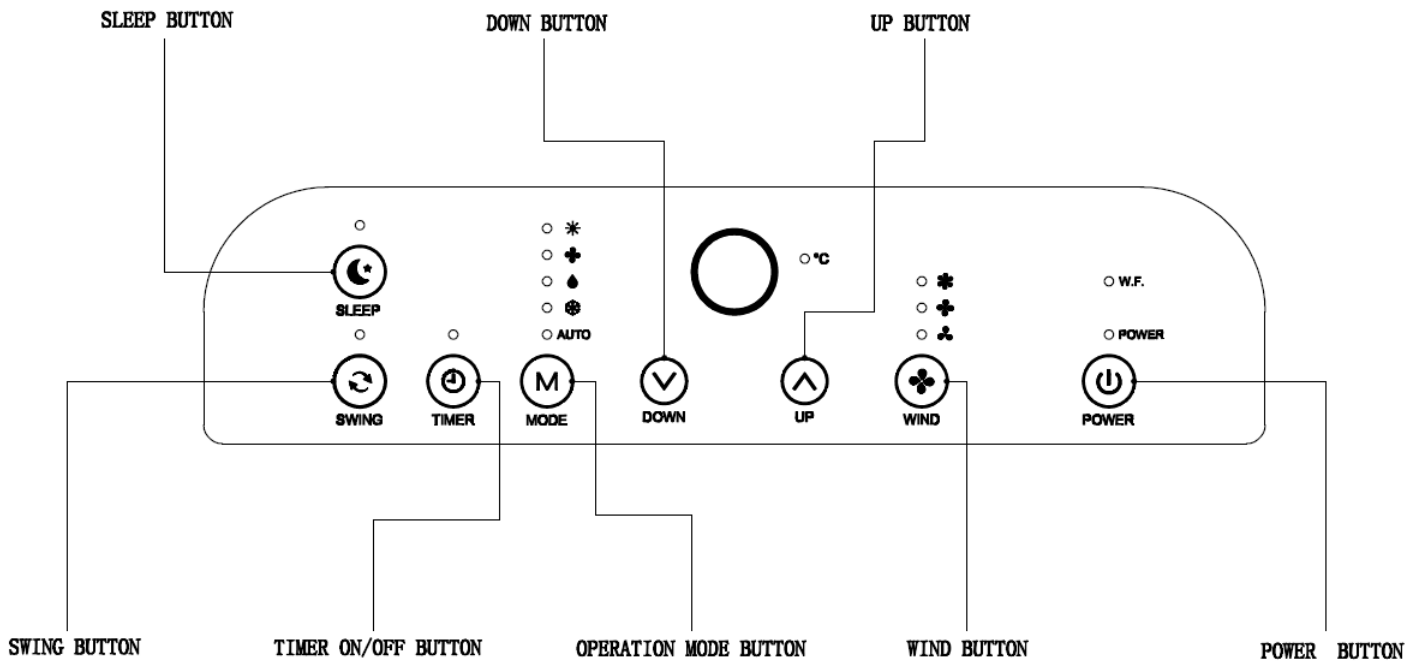

Appearance and function of remote controller

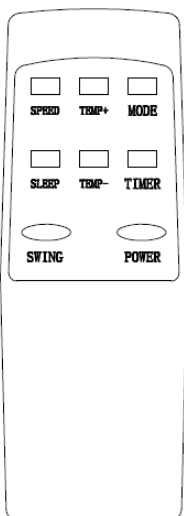

1. POWER	On/Off switch
2. MODE	MODE selector
3. TIMER	Hourly programming
4. SPEED	Fan speed selector
5. TEMP+	Temperature selector up
6. TEMP-	Temperature selector down
7. SLEEP	Night operation selector
8. SWING	Auto air flow selector

Operation introduction

Before starting operations in this section:

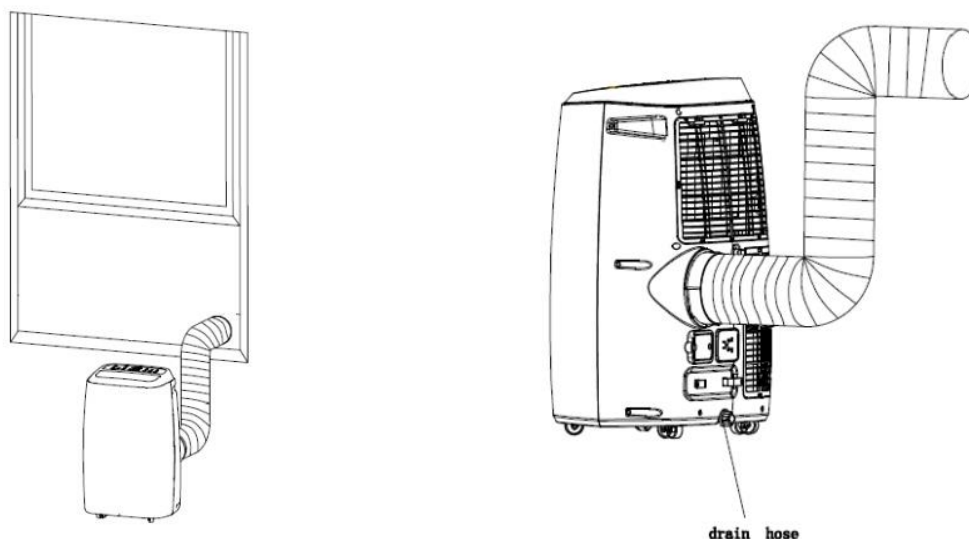

- 1) Find a place where there is power supply nearby.
- 2) Install the exhaust hose, and adjust the window position well.
- 3) Insert the power cord into a grounded AC220~240V/50Hz socket;
- 4) Press the POWER button to turn on the air-conditioner.

1.Before using

Notice:

- Operation temperature range:

/	Maximum cooling	Minimum cooling
DB/WB(°C)	35/24	18/12

/	Maximum heating	Minimum heating
DB/WB(°C)	27/---	7/---

Checkup whether the exhaust hose has been mounted properly.

Cautions for cooling and dehumidifying operations:

- When using functions on cooling and dehumidifying, keep an interval of at least 3 minutes between each POWER.
- Power supply meets the requirements.
- The socket is for AC use.
- Do not share one socket with other appliances.
- Power supply is AC220--240V, 50Hz

2. AUTO MODE

- According to the current room temperature, automatically select the mode: cooling, dehumidifying or fan (see table 1).

Table 1

Room Temperature (Tr)	Tr < 23 °C	23°C ≤ Tr < 26°C	Tr ≥ 26°C
Mode	Heating	Dehumidify	Cooling
Set Temperature	21°C	23°C	25°C

3. Cooling operation

- Press the "Mode" button till the "Cool" icon appears.
- Press the "▲" or "▼" button to select a desired room temperature. (16°C-31°C)
- Press the "WIND" button to select wind speed.

4. Dehumidifying operation

Press the "Mode" button till the "Dehumidify" icon appears.

- Automatically set the selected temperature to current room temperature minus 2°C.
- Automatically set the fan motor to LOW wind speed.

5. Fan operation

- Press the "Mode" button till the "Fan" icon appears.
- Press the "WIND" button to select wind speed.

6. Heating operation

- Press the "Mode" button till the "Heat" icon appears.
- Press the "▲" or "▼" button to select a desired room temperature. (16°C-31°C)
- Press the "WIND" button to select wind speed.

-

7. Timer operation

Timer ON setting:

- When the air-conditioner is OFF, press the "Timer" button and select a desired ON time through the temperature and time setting buttons.
- "Preset ON Time" is displayed on the operation panel.
- ON time can be regulated at any time in 0-24 hours.

Timer OFF setting

- When the air-conditioner ON, press "Timer" button and select a desired OFF time through the temperature and time setting buttons.
- "Preset OFF Time" is displayed on the operation panel.
- OFF time can be regulated at any time in 0-24 hours.

8. SWING (air flow)

After machine turns on, press this key, the louver will swing continuously left and right; by pressing this button again the movement will stop and the louver remain in that position.

9. SLEEP CONTROL FUNCTION

- While in cooling mode, press the SLEEP key to set the temperature. It increases 1 °C after an hour and at most increases 2 °C after 2 hours.
- While in heating mode, press the SLEEP key to set the temperature. It decreases 1 °C after an hour and at most decreases 2 °C after 2 hours.
- Press the SLEEP key again can cancel the setting

10. Drainage

Internal Tank Water Full Alarm Function

The inner water tank in the air-conditioner has one water level safety switches, it controls water level. When water level reaches an anticipated height, the water full indicator lamp lights up. (If water pump is damaged, when the water is full, please remove the rubber blockage at the bottom of unit, and all water will drain outside.)

CONTINUOUS DRAINAGE

- When you plan to leave this unit unused for a long time, please remove the rubber blockage from the drainage hole at the bottom of unit, and connect a drain hose to the lower fixing clip. All the water in the water tank will drain outside.
- You can drain the water as the above when the unit working at the HEAT mode.
- If water pump is damaged, continuous drainage can be used, and under this condition, the water pump is not activated. The unit can also work well.
- If water pump is damaged, intermittent drainage can also be used. Under this condition, when the water full indicator lamp lights up, please connect a drain hose to the lower fixing clip, then all the water in the water tank will drain outside. The unit can also work well.

Installations explanations

1 Installation Explanations:

- A removal air-conditioner shall be installed in the flat and empty place all around. Don't block the air outlet, and the required distance around should be at least 30cm.
- Should not be installed in dry cleaner.
- Socket wiring should be in accordance with the local electric safety requirements.

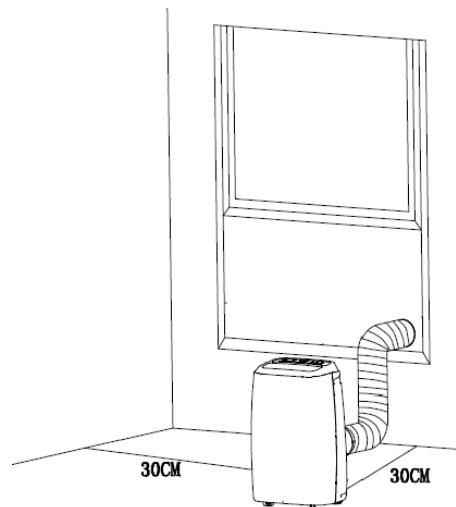

2. Introduction to Exhaust Hose Installation

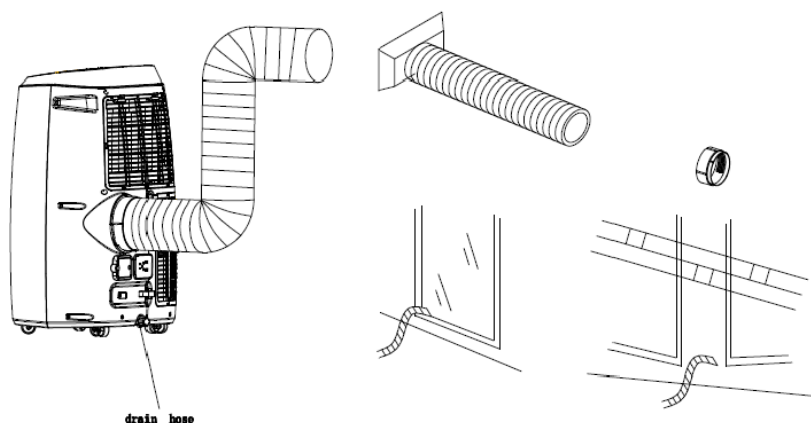

A) Temporary installation

1. Twist both ends of the exhaust hose into the square fixing clip and the flat fixing clip.
2. Insert the square fixing clip into openings at back of the air conditioner (see Fig.9).
3. Put the other end of the exhaust hose to the near windowsill.

Internal Tank Water Full Alarm Function

The inner water tank in the air-conditioner has one water level safety switches, it controls water level. When water level reaches an anticipated height, the water full indicator lamp lights up. (If water pump is damaged, when the water is full, please remove the rubber blockage at the bottom of unit, and all water will drain outside.)

Maintenance explanations

Declaration:

- 1) Before cleaning, be sure to disconnect the unit from any electric supply outlet;
- 2) Do not use gasoline or other chemicals to clean the unit;
- 3) Do not wash the unit directly;
- 4) If the conditioner is damaged, please contact the dealer or repair shop.

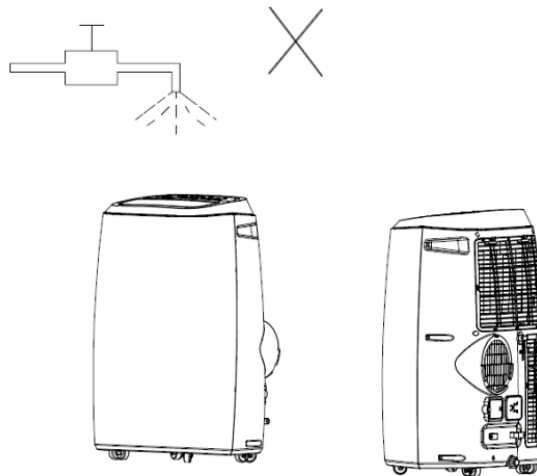

1. Air Filter

- If the air filter becomes clogged with dust/dirt, the air filter should be cleaned once every two weeks.

- Dismounting

Open the air inlet grille and take off air filter.

- Cleaning

Clean the air filter with neutral detergent in lukewarm (40°C) and dry it up in the shade.

Mounting

Putting the air filter into the inlet grille, replace the components as they were.

2. Clean the Air-conditioner Surface

First clean the surface with a neutral detergent and wet cloth, and then wipe it with a dry cloth.

Troubleshooting

Troubles	Possible Causes	Suggested Remedies
1. UNIT DOES NOT START WHEN PRESSING POWER BUTTON	- Water full indicator lamp blinks, and water tank is full.	Dump the water out of the water tank.
	- Room temperature is higher than the setting temperature. (Electric heating mode)	Reset the temperature
	Room temperature is lower than the setting temperature. (Cooling mode)	Reset the temperature
2. Not cool enough	The doors or windows are not closed.	Make sure all the windows and doors are closed.
	There are heat sources inside the room.	Remove the heat sources if possible
	Exhaust air hose is not connected or blocked.	Connect or clean the exhaust air hose.
	Temperature setting is too high.	Reset the temperature
	Air inlet is blocked.	Clean the air inlet.
3. Auto Power-Off in heating mode	Heating protection, when the temperature at the air outlet exceeds 70°C, the unit will power off automatically.	Restart the unit at enough lower room temperature.
4. Noisy	The ground is not level or not flat enough	Place the unit on a flat, level ground if possible
	The sound comes from the flowing of the refrigerant inside the air conditioner	It is normal.
5. E0 Code	Room temperature sensor failed	Replace room temperature sensor (the unit can also work without replacement.)
6. E3 Code	Pipe temperature sensor failed	Replace pipe temperature sensor (the unit can also work without replacement.)
7. E2 /E4 Code	Water tank full	Please empty the water tank.

The product or equipment contains fluorinated greenhouse gas.

Coolant: R290

Quantity in kg: 0,21

Global Warming Potential: 3

Recycling



This marking indicates that this product should not be disposed with other household wastes throughout the EU. To prevent possible harm to the environment or human health from uncontrolled waste disposal, recycle it responsibly to promote the sustainable reuse of material resources. To return your used device, please use the return and collection systems or contact the retailer where the product was purchased. They can take this product for environmentally safe recycling.

Guarantee

This product is guaranteed for 24 months granted. Your warranty is valid if the product is used in accordance to the instructions and for the purpose for which it was created.

The warranty does not apply if the error is due to improper use or handling, neglect, incorrect installation or storage, inappropriate connection or installation. The warranty is invalidated if alterations or repairs are made by unauthorized people. The warranty is also invalidated in the following cases:

- If a product for domestic use is used in an industrial environment.
- If the product is not working any more due to another device in your home.
- If the product's serial number has been removed.
- If the product has been opened for a reason other than the intended use.
- The product has been repaired by an unauthorized service center or if non-original spare parts or accessories have been used for the repair.

In case you want to make use of the warranty or in case of damage, please contact your local store that you bought the product. In addition, the original purchase (invoice, sales slip or receipt) is to be submitted with the date of purchase, the name of the retailer and the item number of the product. Our warranty covers only manufacturing defects. The warranty does not cover normal wear and tear due to use.

Recommendation:

- If the product does not work as intended, first check if the cause is other reasons, such as incorrect handling.



Ithomis Str. 6, Chalandri, GR-15231

Athens - Greece

Tel: +30210 6715510 / +30211 7007269/ +30211 7007270

Fax: +302106542877

Website: www.ecofer.com.gr