



MORRIS

MAF-8003

Please read this manual carefully before use this product

USER MANUAL

AIR FRYER with steam assist function

Instructions Manual



MODEL: MAF-8003

Save These Instructions

For Household use only

When using electrical appliances, basic safety precautions should always be followed.

Do not use the air fryer until you have read this manual thoroughly.

IMPORTANT SAFEGUARDS

When using electrical appliances, basic safety precautions should always be followed, including:

- **NEVER IMMERGE** the main unit's housing, which contains electrical components and heating elements, in water.
Do not rinse under the tap.
- **TO AVOID ELECTRICAL SHOCK, DO NOT** put liquid of any kind into the main unit housing containing the electrical components.
- If the plug does not fit fully into the outlet, reverse the plug. If it still does not fit, contact a qualified electrician. **DO NOT ATTEMPT** to modify the plug in any way.
- **MAKE SURE** the appliance is plugged into a wall socket. Always make sure that the plug is inserted into the wall socket properly.
- To prevent food contact with the interior upper screen and heat element, **DO NOT OVERFILL** the basket.
- **DO NOT COVER** the air intake vent or air outlet vent while the air fryer is operating. Doing so will prevent even cooking and may damage the unit or cause it to overheat.
- **NEVER POUR** oil into the basket. Fire and personal injury could result.
- While cooking, the internal temperature of the unit reaches several hundred degrees Centigrade. **TO AVOID PERSONAL INJURY**, never place hands inside the unit unless it is thoroughly cooled down.
- This appliance is **NOT INTENDED FOR USE** by persons with reduced physical, sensory, or mental capabilities, or lack of experience and knowledge, unless they are **UNDER THE SUPERVISION** of a responsible or have been given proper instruction in using the appliance. This appliance is **NOT INTENDED FOR USE** by children.
- While cooking, **DO NOT PLACE** the appliance against a wall or against other appliances. Leave at least 15cm free space on the back and sides and above the appliance. Do not place anything on top of the appliance.
- **DO NOT USE** this unit if the plug, the power cord, or the appliance itself is damaged in any way.
- **DO NOT PLACE** the unit on stovetop surfaces.
- If the power cord is damaged, **YOU MUST HAVE IT REPLACED** by the manufacturer, its service agent, or a similarly qualified person in order to avoid hazard.
- Keep the appliance and its power cord **OUT OF THE REACH** of children when it is in operation or in the "cooling down" process.
- **KEEP THE POWER CORD AWAY** from hot surfaces. **DO NOT PLUG** in the power cord or operate the unit with wet hands.
- **NEVER CONNECT** this appliance to an external timer switch or separate remote-control system.
- **NEVER USE** this appliance with extension cord of any kind.
- **DO NOT OPERATE** this appliance on or near combustible materials such as tablecloths and curtains.
- **DO NOT USE** the air fryer for any purpose other than described in this manual.
- **NEVER OPERATE** the appliance unattended.
- When in operation, air is released through the air outlet vent.
KEEP YOUR HANDS AND FACE at a safe distance from the air outlet vent.
Also avoid the air while removing the basket from the appliance.

IMPORTANT SAFEGUARDS

- The unit's outer surfaces may become hot during use. Use oven mitts when handling hot components. Use oven mitts when handling hot surfaces.
- Should the unit emit black smoke, UNPLUG IMMEDIATELY and wait for smoking to stop before removing air fryer contents.
- When time has run out, cooking will stop but the fan will continue running for 20 seconds to "cool down" the unit.
- Always operate the appliance on a horizontal surface that is level, stable, and non combustible.
- This appliance is intended for normal household use only. It is not intended for use in commercial or retail environments.

Overheating Protection

If the inner temperature control system fails, the overheating protection system will be activated and the unit will not function. In case this happens, unplug the power cord. Allow time for the unit to cool completely before restarting or storing.

Automatic Shut-off

The appliance has a built in "shut-off" device, that will automatically shut down the unit when the timer LED reaches zero. You can manually switch off the appliance by selecting the power button. The fan will continue running for 20 seconds to "cool down" the unit.

If the air fryer is used improperly or for professional or semi-professional purposes or if it is not used according to the instructions in the user manual, the warranty becomes invalid and we will not be held liable for damages.

- Always unplug the appliance after use.
- Let the appliance cool down for approximately 30 minutes before handling, cleaning or storing.
- Make sure the ingredients prepared in this unit come out cooked to a golden-yellow color rather than dark or brown. Remove burnt remnants.

Electric Power

If the electrical circuit is overloaded with other appliances, your new unit may not operate properly. It should be operated on a dedicated electrical circuit.

Electromagnetic Fields (EMF)

This appliance complies with all standards regarding electromagnetic fields (EMF). If handled properly and according to the instructions in this user manual, the appliance is safe to use based on scientific evidence available today.

General description (Fig.1)

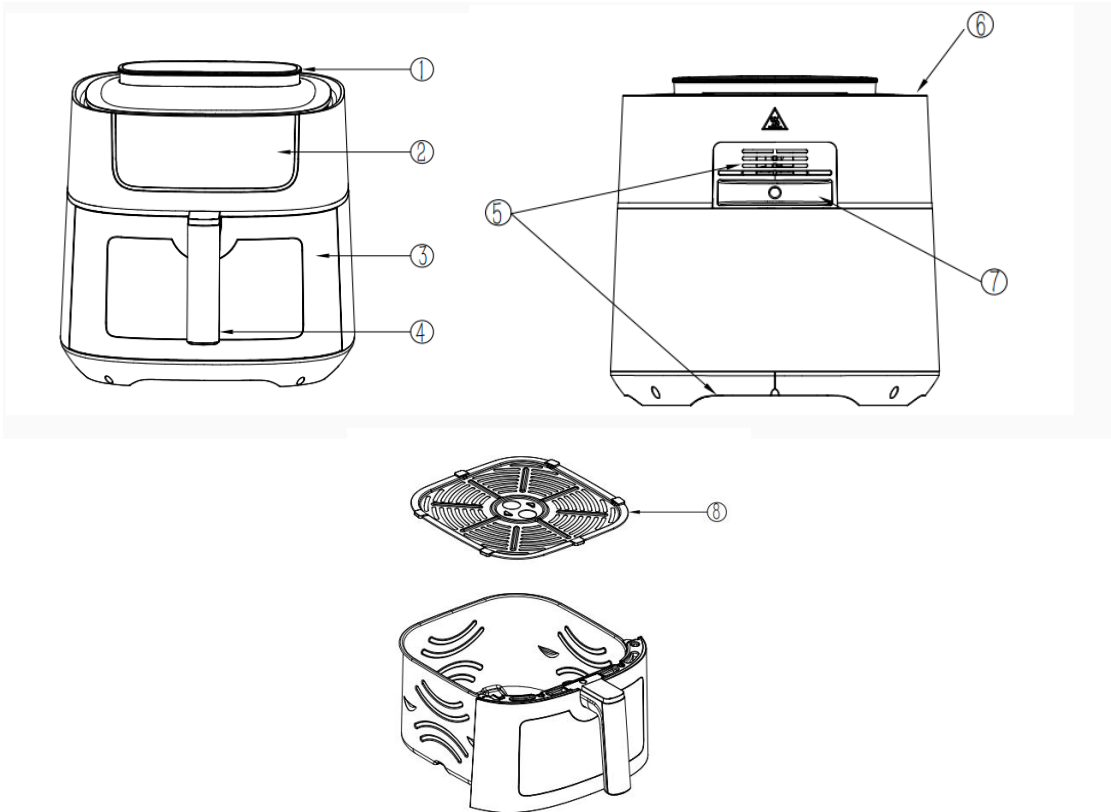

1. Water Tank

2. Digital Touch Control Panel

3. Basket

4. Basket handle

5. Air outlet openings

6. Air inlet

7. Mains cord

8. Frying tray

Attaching the fry basket handle:

The fry basket handle might come disassembled in your appliance's packaging. To attach the fry basket handle:

1. Remove the paper label. Pull the fry basket out of the appliance.
2. Slide the attachment point on the handle downward until it clicks in to place.
3. The fry basket handle should lock into place and should not detach once it is locked into place.



Removing the fry basket handle:

Normally the handle is not suggested to be removed from the basket after you assemble it, but if you do need to remove the fry basket handle, then you can follow below steps:

1. Use a tool, such as a screwdriver, to lift the silicone on the fry basket handle.
2. Align the tool with the hole and push down, then tilt the tool inward.
3. Grab the handle with your hand and pull it out.



Inserting the frying tray

1. Place the frying tray in the basket. The frying tray's adjustable height lets you place food closer to the heating element for broiling. You can also use it to make the total size of the basket smaller when cooking smaller quantities of food.
2. To raise the frying tray closer to the heating element, position the edges of the frying tray(see Fig.i) on the frying tray holders(see Fig. j). To use the frying tray on the bottom of the basket, rotate the frying tray so that the frying tray's edges slide past the frying tray holder, and push the frying tray to the bottom of the basket(see Fig.k).
3. Slide the basket into the appliance. If the basket is placed properly, it will click into place.
Note: This appliance cooks using hot air. Do not fill the basket with oil or frying fat.

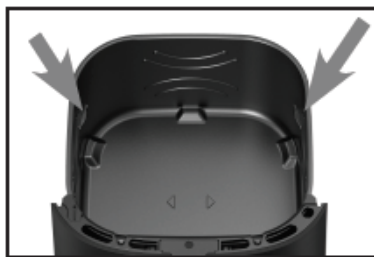

Fig.i



Fig.j



Fig.k

Before first use

1. Remove all packaging materials and stickers or labels.
2. Clean the basket and cooking trivet with hot water, with some washing liquid and a non-abrasive sponge. These parts are safe to be cleaned in dishwasher. It is recommended to wipe / wash and clean them by hand to ensure a longer lasting life.
3. Wipe inside and outside of the appliance with a clean cloth. There is no need to fill the pan with oil or frying fat as the appliance works with hot air only.

Using the appliance

1. Connect the mains plug into an earthed wall socket.
2. Carefully pull the basket out of the air fryer
3. Place the ingredients in the basket.
4. Slide the basket into the AIR FRYER

Note: Do not exceed the MAX indication (see section “settings” in this chapter), as it may affect the cooking quality of the food.

Caution: Do not touch the basket during and in short-time after use, as it gets very hot. Only hold the basket by the handle.

Do not fill the pan with oil or any other liquid.

5. Finger touch Power on/off
6. Touch Menu to choose functions (totally 8 functions).



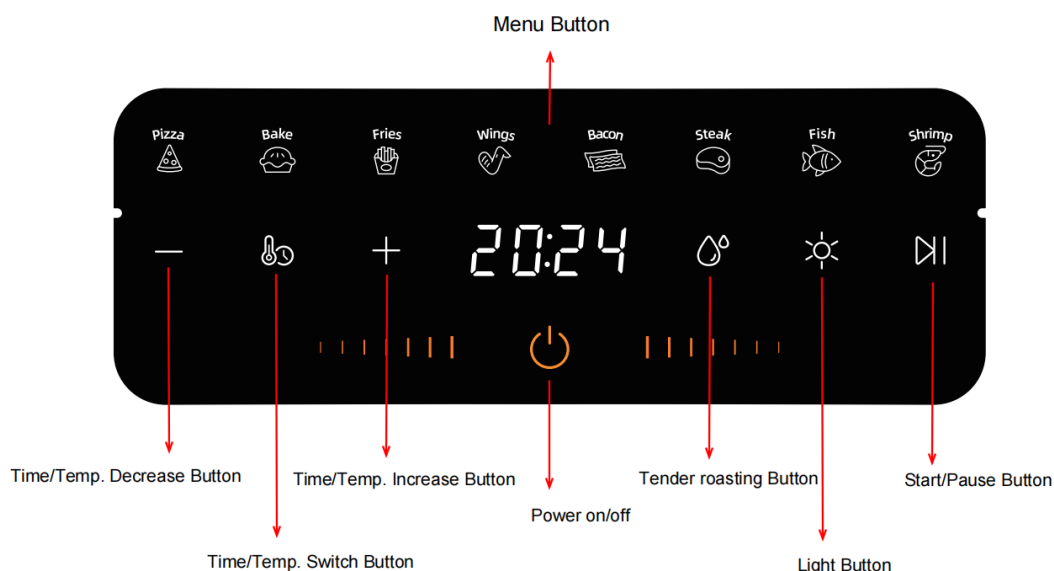





Control panel presentation





Note: 8 functions are provided:

PIZZA, BAKE, FRIES, WINGS, BACON, STEAK, FISH, SHRIMP

Menu presetting:

Preset	Icon	Temp.(°C)	Time (min)	Tender Roast
Pizza		185	15	
Bake		160	20	
Fries		200	20	√
Wings		200	18	√
Bacon		175	12	√
Steak		200	20	√
Fish		195	10	√
Shrimp		160	10	√



After touching menu button, you can choose menu you like. After choosing the function, press Start/Pause button  to start cooking.

During the cooking process, if you want to adjust time or temperature, kindly press the Time/temperature button  first.

When the display on screen shows time, then press the +/- button to increase/decrease cooking time (1 minute per one press).

When the display on screen show the temperature, then press +/- button to increase/decrease temperature (5 degrees per one press).

Operations:

Start/Pause button : During the hot air frying process, the LED lamp will be running, then if press this button, the LED lamp will blink. At this stage, this button acts as 'pause' function. In the pause state, you can change menu to choose other presetting. For example, you want to change fries to bake: first press the Pause button , then touch menu button to switch to different cooking function. If you press this button again, the air fryer will continue cooking. At this stage, this button acts as 're-start' function.

If you don't select any preset, unit will work according to the default temperature and time (180°C and 15 minutes).

Note: when the cooking cycle has reached its halfway point, the buzzer will sound three times as a reminder. This halfway time gives you the opportunity to check the status of the food.

For example, like fries and steak, you can shake or flip your food into the appliance after the reminder beeps, which helps to ensure even cooking.

Light button : Touching this button, the inside light will be up; touching this button again and the light will be off. The light will automatically turn off 30 seconds later.

Tender roasting button: 

By touching this button, the water spray tender roasting function is activated and the tender roasting button flashes.

The Tender roasting function is a cycle of 15sec. repeated every 5 min.

Water is added (spraying) every 5 minutes for 15 seconds each time.

The water spray Tender roasting function can only be set in the paused state.

Pizza and cake / egg tart do not need steam function, so the Tender roasting button cannot be chosen on those programs.

Using the water tank:

The water tank is required for the Tender roasting function.

It needs to be filled before each use and placed in the water tank mount.

Remove the water tank from the unit.

Open the water tank cap.

Add tap water to the water tank.

Add the water tank cap to the water tank.

Place the water tank to the water tank mount on the top of the unit.

Clean the water tank if it is unused for an extended period.

Residual water and other liquids are prone to mildew.

Do not put anything except the water into water tank to avoid malfunctions.

8. Some ingredients require to shake halfway during the preparation time (see section 'Settings' in this chapter). By this way, pull the pan out of the appliance by the handle and shake it. Then slide the pan back into the air fryer.

9. Machine will have Auto ready bell after cooking. When bell rings 5 times, this means that the cooking cycle is finished. Pull the pan out of the appliance and place it on the heat-resistant holder.

Note: After the time ends, the heating element stops working, but the fan will continue to run about 20 seconds to blow away the hot air as safety. Finally, the timer bell will ring 5 times as the ending alarm.

10. Check if the ingredients are ready.

Note: If the ingredients are not ready yet, simply slide the pan back into the appliance. Press the temperature control knob to adjust Temperature setting, and press the Timer control button to adjust time setting. And then press the Start button to run the appliance.

11. To remove ingredients, (e.g. beef, chicken, meat, any ingredients with no excess oil from ingredients collected on the bottom of the pan), please use a tong to remove them one by one.

Note: Be careful if you want to turn the basket over, the oil collected on the bottom of the basket will leak onto the ingredients.

12. To remove ingredients (e.g. chips, vegetable or ingredients with no excess oil from the ingredients), please turn off the pan and pour ingredients to tableware.

Tip: To remove large or fragile ingredients, lift the ingredients out of the pan by a pair of tongs.

13. When a batch of ingredients is ready, the fryer is instantly ready for preparing another batch.

Cooking settings

This table below will help you to select the basic settings for the ingredients.

Note: Keep in mind that these settings are indications. As ingredients differ in origin, size, shape and brand, we cannot guarantee the best setting for your ingredients.

As the **Speedy Cook technology** reheats the air inside the appliance instantly, pulling the pan briefly out of the appliance during hot air frying barely disturbs the process.

	Min-Max (g)	Time (Min)	Temp °C	Shake	Remark
French fries					
Thin frozen fries	300-700	9-16	200	Y	
Thick frozen fries	300-700	11-20	200	Y	
Home-made fries (8X8mm)	300-800	10-16	200	Y	Add 1/2 tbsp of oil
Homemade potato wedges	300-800	18-22	180	Y	Add 1/2 tbsp of oil
Home-made potato cubes	300-750	12-18	180	Y	Add 1/2 tbsp of oil
	250	15-18	180	Y	
Potato gratin	500	15-18	200	Y	
Steak	100-500	8-12	180		
Meat chops	100-500	10-14	180		
Hamburger	100-500	7-14	180		
Sausage roll	100-500	13-15	200		
Drumsticks (chicken legs)	100-500	18-22	180		
Chicken breast	100-500	10-15	180		
Snacks					
Spring rolls	100-400	8-10	200	Y	Use oven-ready
Frozen chicken nuggets	100-500	6-10	200	Y	Use oven-ready
Frozen fish fingers	100-400	6-10	200		Use oven-ready
Frozen bread crumbed	100-400	8-10	180		Use oven-ready
Stuffed vegetables	100-400	1-10	160		
Cake	300	20-25	160		Use baking tin
Quiche	400	20-22	180		Use baking tin/oven dish
Muffins	300	15-18	200		Use baking tin
Sweet snacks	400	1-20	160		Use baking tin/oven dish

Tips

- Small ingredients usually require a slightly shorter preparation time than larger ingredients.
- A larger amount of ingredients only requires a slightly longer preparation time, a smaller amount of ingredients only requires a slightly shorter preparation time.

Tips

- Shaking smaller ingredients halfway during the preparation time optimizes the end result and can help prevent unevenly fried ingredients.
- Add some oil to fresh potatoes and fry your ingredients for another few minutes then for a crispier result.
- Do not prepare extremely greasy ingredients such as sausages in the air fryer.
- Snacks that can be prepared in an oven can also be prepared in the air fryer.
- The optimal amount to prepare crispy fries is 500 grams.
- Use pre-made dough to get snacks quickly and easily. Pre-made dough also requires a shorter preparation time than home-made dough.
- Place a baking tin or oven dish in the fryer basket if you want to bake a cake or quiche or if you want to fry fragile ingredients or filled ingredients.
- You can also use the air fryer to heat ingredients. To heat ingredients, set the temperature to 150°C for up to 10 minutes.

Making home-made fries

To make home-made fries, follow the steps below:

1. Peel and slice the potatoes.
2. Wash the potato sticks thoroughly and dry them with kitchen paper.
3. Pour 1/2 tablespoon of olive oil in a bowl, put the sticks on top and mix until the sticks are coated with oil.
4. Remove the sticks from the bowl with your fingers or a kitchen utensil so that excess oil stays back in the bowl. Put the sticks in the basket.
5. Fry the potato sticks according to the instructions in this chapter.

NOTE FOR THE NON-STICK BAKING PAPERS:

- The use of non-stick paper makes cooking easier and leaves the device clean.
- The use of kitchen non-stick paper is optional.
- The baking/cooking time of some foods might be affected because the air flow is also affected.

Cleaning

Clean the appliance after every use.

Do not clean the basket, frying tray and the inside of the appliance with metal kitchen utensils or abrasive cleaning materials, as this may damage the non-stick coating of them.

1. Remove the mains plug from the wall socket and wait for the appliance to cool down.

Note: Remove the basket to let the fryer cool down more quickly.

2. Wipe the outside of the appliance with a moist cloth.
3. Clean the pan and basket with hot water, some washing-up liquid and a non-abrasive sponge.

You can remove any remaining dirt by degreasing liquid.

Note: The basket and frying tray are dishwasher-proof. However, **it is recommended to wipe / wash and clean them by hand to ensure a longer lasting life.**

Tip: If dirt is stuck to the basket or the bottom of the pan, fill the pan with hot water with some washing-up liquid. Put the basket in the pan and let the pan and the basket soak for about 10 minutes.

4. Clean the inside of the appliance with hot water and non-abrasive sponge.
5. Clean the heating element with a cleaning brush to remove any food residues.

Storage

1. Unplug the appliance and let it cool down thoroughly.
2. Make sure all parts are clean and dry.

Troubleshooting

Problem	Possible Cause	Solution
The air fryer does not work	The appliance is not plugged in	Put the mains plug in an earthed wall socket
	You have not set the Timer	Turn the timer knob to the required peroration time to switch on the appliance
The ingredients fried with the air fryer are not done	The amount of ingredients in the basket is too big.	Put smaller batches of ingredients in the basket. Smaller batches are fried move evenly
	The set temperature is too low.	Turn the temperature control knob to the required Temperature setting (see section 'Settings' in chapter 'Using the appliance').
The ingredients are fried unevenly in the air fryer	Certain types of ingredients need to be shaken halfway through the cooking time	Ingredients that lie on top of or across each other (e.g. fries) need to be shaken halfway through the cooking time. See section 'Settings' in chapter 'Using the appliance'
Fried snacks are not crispy when they come out of the air fryer	You used a type of snacks meant to be prepared in a traditional deep fryer	Use oven snacks or lightly brush some oil onto the snacks for a crisper result.
I cannot slide the pan into the appliance properly	There are too many ingredients in the basket	Do not fill the basket beyond the MAX indication
	The basket is not placed in the pan correctly	Push the basket down into the pan until you hear a Click.
White smoke comes out from the appliance	You are preparing greasy ingredients	When you fry greasy ingredients in the fryer, a large amount of oil will leak into the pan. The oil produces white smoke and the pan may heat up more than usual. This does not affect the appliance or the end result.
	The pan still contains grease residues from previous use	White smoke is caused by grease heating up in the pan. Make sure you clean the pan properly after each use.
Fresh fries are fried unevenly in the air fryer	Wrong type of potato (not for frying) is being used.	Use fresh, firm, yellow potatoes. Use cut sticks and pat dry to remove excess starch. Make sure that they stay firm during frying.
	You did not rinse the potato sticks properly before you fried them.	Rinse the potato sticks properly to remove starch from the outside of the sticks.
Fresh fries are not crispy when they come out of the air fryer	The crispiness of the fries depends on the amount of oil and water in the fries.	Make sure you dry the potato sticks properly before you add the oil.
		Cut the potato sticks smaller for a crispier result
		Add slightly more oil for a crisper result.

NOTICE ABOUT RECYCLING



Your product is designed and manufactured with high quality materials and components which can be recycled and reused. This symbol means that electrical and electronic equipment, at their end-of-life, should be disposed of separately from your household waste. Please dispose of this equipment at your local community waste collection/ recycling centre.

In the European Union there are separate collection systems for used electrical and electronic products.

Please help us to conserve the environment we live in!

DECLARATION OF CONFORMITY

Herewith, we state that this product complies with the requirements of below directives:

EMC-Directive: 14 / 30 / EU

Low Voltage Directive: 14 / 35 / EU

ErP Directive 09 / 125 / EC

CE Marking: 93 / 68 / EEC

RoHS Directive: 11 / 65 / EU Delegated Directive (EU) 15 / 863

The detailed declaration of conformity can be found at www.morris.gr





KALLIOPI KARYDA & CO., LP
87A, 17th November str.
55535 Pylea Thessaloniki
Tel. 2316006600 | Fax 2316006650
www.morris.gr