

vtech®

**User's manual
BM2600**

**Safe & Sound
Full Color Video and Audio Monitor**



**Model:
BM2600**

For product support
please call: 1 300 369 193

Congratulations

on purchasing your new VTech product. Before using this product, please read **Important safety instructions** on page iii of this user's manual.

This user's manual has all the feature operations and troubleshooting necessary to install and operate your new VTech product. Please review this user's manual thoroughly to ensure proper installation and operation of this innovative and feature rich VTech product.

Product introduction

BM2600 is a video and audio monitor which consists of one baby unit (**BM2600 BU**) and one parent unit (**BM2600 PU**).

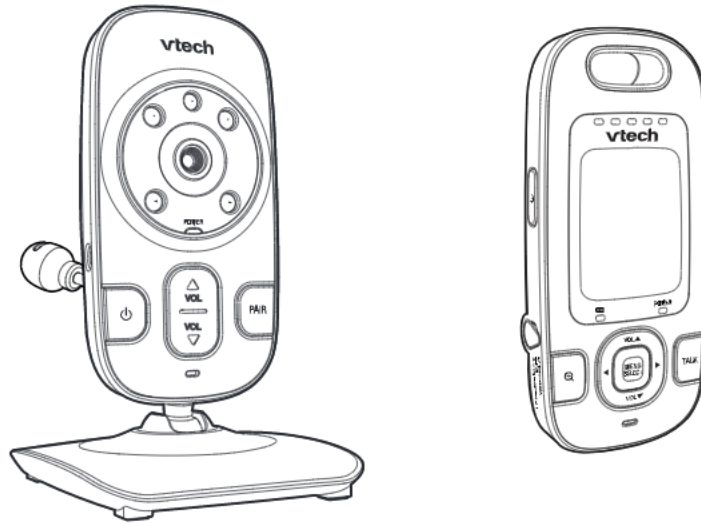

The parent unit may be shipped with protective stickers covering the displays. Remove the protective sticker before use.

Important safety instructions

When using your equipment, basic safety precautions should always be followed to reduce the risk of fire, electric shock and injury, including the following:

1. Follow all warnings and instructions marked on the product.
2. Adult setup is required.
3. This product is intended as an aid. It is not a substitute for responsible and proper adult supervision and should not be used as such.
4. This product is not intended for use as a medical monitor.
5. Do not use this product near water. For example, do not use it next to a bath tub, wash bowl, kitchen sink, laundry tub or swimming pool, or in a wet basement or shower.
6. CAUTION: Use only the battery indicated in this user's manual. There may be a risk of explosion if a wrong type of battery is used for the parent unit. Do not dispose of batteries in a fire.
7. Use only the adapters included with this product. Incorrect adapter polarity or voltage can seriously damage the product.
Baby unit power adapter: Input 100-240V AC 150mA 50/60Hz;
output: 6V DC 600 mA
Parent unit power adapter: Input 100-240V AC 150mA 50/60Hz;
output: 6V DC 600 mA
8. The power adapters are intended to be correctly oriented in a vertical or floor mount position. The prongs are not designed to hold the plug in place if it is plugged into a ceiling, under-the-table or cabinet outlet.
9. Unplug this product from the wall outlet before cleaning. Do not use liquid or aerosol cleaners. Use a damp cloth for cleaning.
10. Unplug the power cords before replacing the battery.
11. Do not cut off the adapters to replace them with other plugs, as this causes a hazardous situation.
12. Do not allow anything to rest on the power cords. Do not install this product where the cords may be walked on or crimped.
13. This product should be operated only from the type of power source indicated on the marking label. If you are not sure of the type of power supply in your home, consult your dealer or local power company.

Important safety instructions (continued)

14. Do not overload wall outlets or use an extension cord.
15. Do not place this product on an unstable table, shelf, stand or other unstable surfaces.
16. This product should not be placed in any area where proper ventilation is not provided. Slots and openings in the back or bottom of this product are provided for ventilation. To protect them from overheating, these openings must not be blocked by placing the product on a soft surface such as a bed, sofa or rug. This product should never be placed near or over a radiator or heat register.
17. Never push objects of any kind into this product through the slots because they may touch dangerous voltage points or create a short circuit. Never spill liquid of any kind on the product.
18. To reduce the risk of electric shock, do not disassemble this product, but take it to an authorized service facility. Opening or removing parts of the product other than specified access doors may expose you to dangerous voltages or other risks. Incorrect reassembling can cause electric shock when the product is subsequently used.
19. You should test the sound reception every time you turn on the units or move one of the components.
20. Periodically examine all components for damage.
21. Be aware of possible loss of privacy while using public airwaves. Conversations may be picked up by other nursery monitors, cordless phones, scanners, etc.
22. Children should be supervised to ensure that they do not play with the product.
23. The product is not intended for use by persons (including children) with reduced physical, sensory or mental capabilities, or lack of experience and knowledge, unless they have been given supervision or instruction concerning use of the appliance by a person responsible for their safety.

SAVE THESE INSTRUCTIONS

Cautions

1. Use and store the product at a temperature between 0°C and 40°C.
2. Do not expose the product to extreme cold, heat or direct sunlight. Do not put the product close to a heating source.
3. The battery pack should not be exposed to excessive heat such as bright sunshine or fire.
4. Make sure the baby unit and the adapter cord are always out of reach of the baby, at least 1 metre away from the baby or crib, to avoid a possible strangulation hazard.
5. Never place the baby unit inside the baby's crib or playpen.
6. Never cover the baby unit or parent unit with anything such as a towel or a blanket.
7. Other electronic products may cause interference with your video and audio monitor. Try installing your video and audio monitor as far away from these electronic devices as possible: wireless routers, radios, cellular telephones, intercoms, room monitors, televisions, personal computers, kitchen appliances and cordless telephones.

Table of contents

Getting started	1	Lullaby control on the parent unit	26
Parts checklist	1	Temperature format.....	26
Baby unit installation	2	Zoom	26
Baby unit installation options	3	Talk function.....	27
Parent unit battery installation.....	5	Night vision.....	27
Parent unit installation	8	Portable use of parent unit.....	28
Parent unit battery charging	9	Appendix.....	29
Baby unit overview	10	Troubleshooting	30
Parent unit overview	12	Operating range.....	35
Parent unit display icons	16	Maintenance	35
Parent unit main menu icons ...	18	Customer service and product warranty	36
Positioning the baby monitor...	20	Technical specifications.....	38
Operating range	21	Index	39
Audio settings	21		
Test your baby monitor before use.....	21		
Using your baby monitor	22		
Power on or off the baby unit...	22		
Power on or off the parent unit...	22		
Turn on or off the parent unit screen.....	22		
Adjust the speaker volume for baby unit.....	22		
Adjust the speaker volume for parent unit	22		
Adjust the LCD brightness of the parent unit	23		
Adjust the sound sensitivity of the baby unit.....	24		
Turn on or off the sound activation	25		

Getting started

Parts checklist

Check to make sure the package contains the following items. Save your sales receipt and original packaging in the event warranty service is necessary.

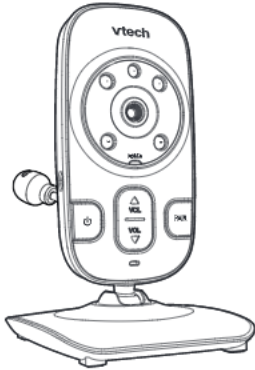

Baby unit
(BM2600 BU)

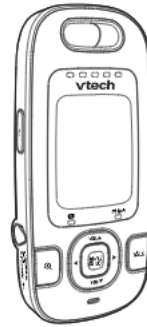

Parent unit
(BM2600 PU)

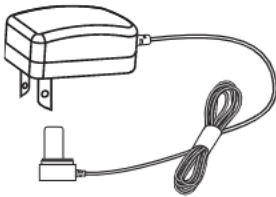

2 Power adapters



Battery

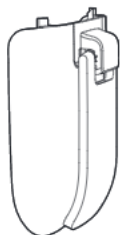

Battery door

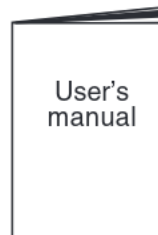

User's manual

note

To purchase replacement batteries or power adapters, please call VTech on 1 300 369 193.

Getting started

Baby unit installation

You can power up the baby unit by connecting it to AC power.

Install the baby unit as shown below.

Bundle the power adapter cord neatly with a twist tie. The baby unit turns on when it is powered up.

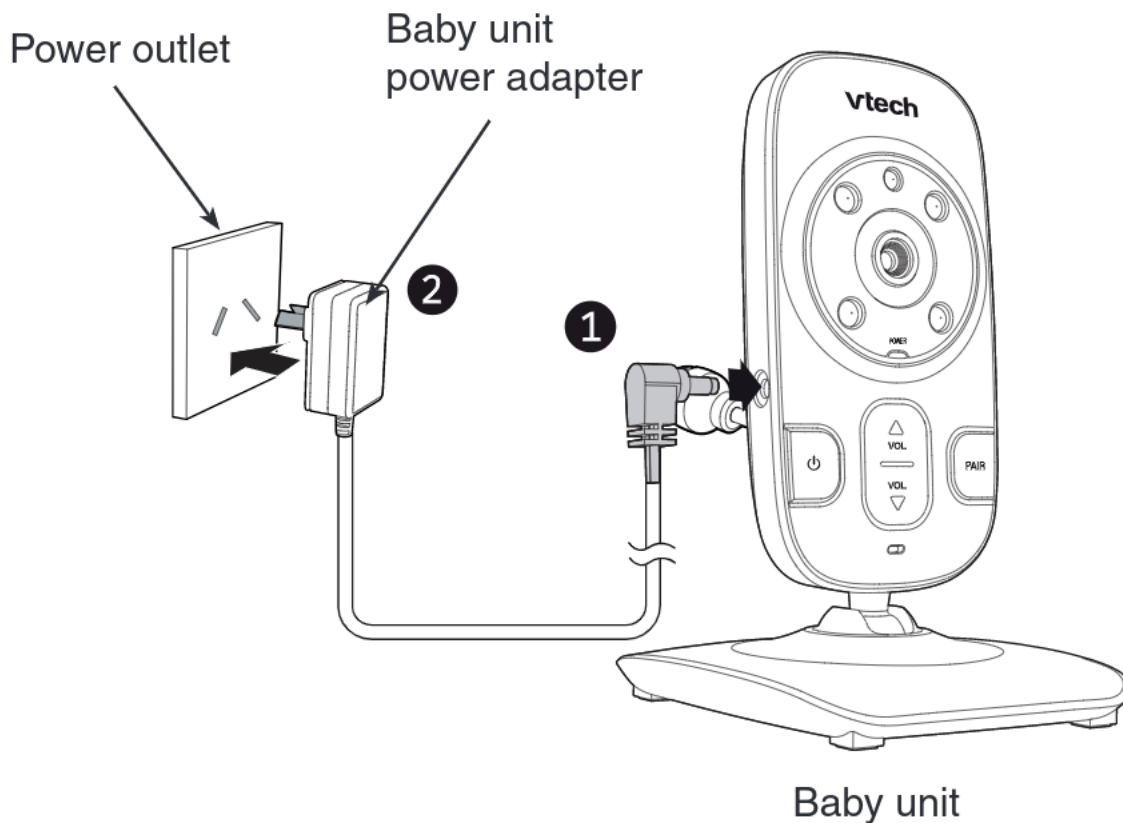

note

- Use only the baby unit power adapters supplied with this product. To order a replacement, contact VTech on 1 300 369 193.
- The baby unit power adapters are intended to be correctly oriented in a vertical or floor mount position. The prongs are not designed to hold the plug in place if it is plugged into a ceiling, under-the-table or cabinet outlet.
- Make sure the baby unit and the power adapter cord are out of reach of children.

Getting started

Baby unit installation options

The baby unit is ready for tabletop use. Use the provided wall mount if you want to mount it on a wall. Make sure to test the reception and the baby unit position before completing the wall mounting installation (see **Test your baby monitor before use** on page 21).

Tabletop to wall mount installation

note

Check for reception strength and camera angle before drilling the holes.

1. Pan or tilt to adjust the baby unit angle.



2. Use a pencil to mark two holes in parallel. Make sure they are the same distance apart as the wall mount at the bottom of the baby unit.

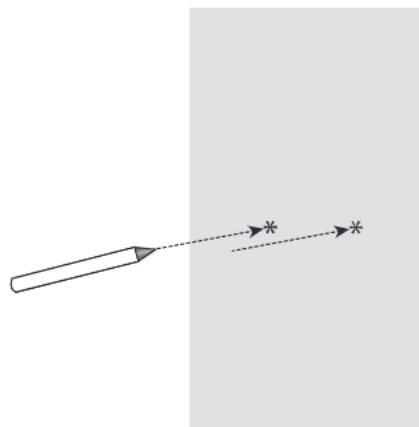

Getting started

Baby unit installation options (continued)

3. Drill two holes in the wall (7/32" drill bit). If you drill the holes into a stud, insert the screws into the holes. Tighten the screws until only 1/4 inch of the screws are exposed.

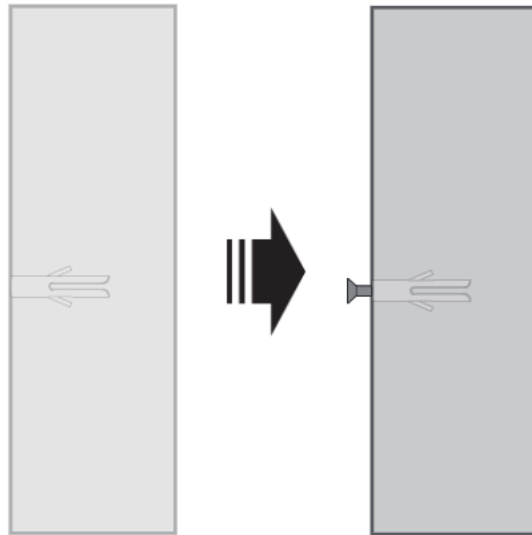

4. Align the holes on the wall mount with the screws on the wall. Slide the wall mount down until it locks into place.

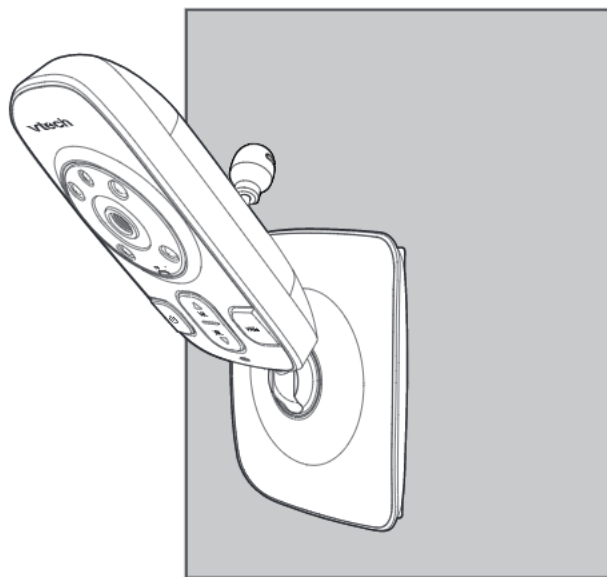

Getting started

Parent unit battery installation

You can power up the parent unit by connecting it to AC power or to the rechargeable battery provided. Even if the parent unit is connected to AC power, we recommend you also install the battery. This guarantees continual operation in case of a power outage.

Install the battery as shown below.

1. Push the detent of the battery compartment cover and lift the cover to open.

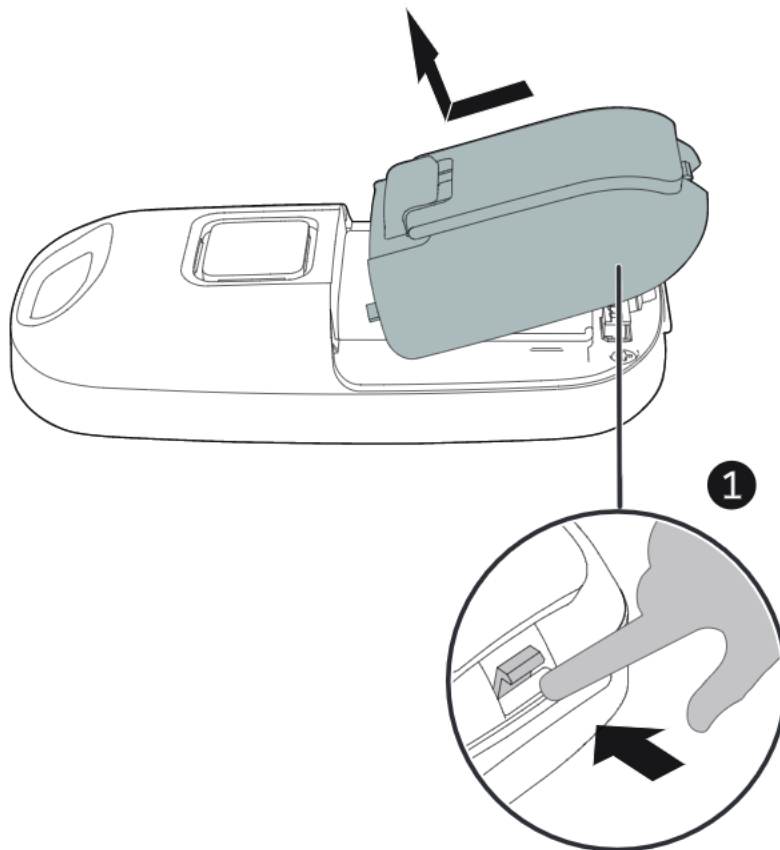

Getting started

Parent unit battery installation (continued)

2. Plug the battery connector securely into the socket.

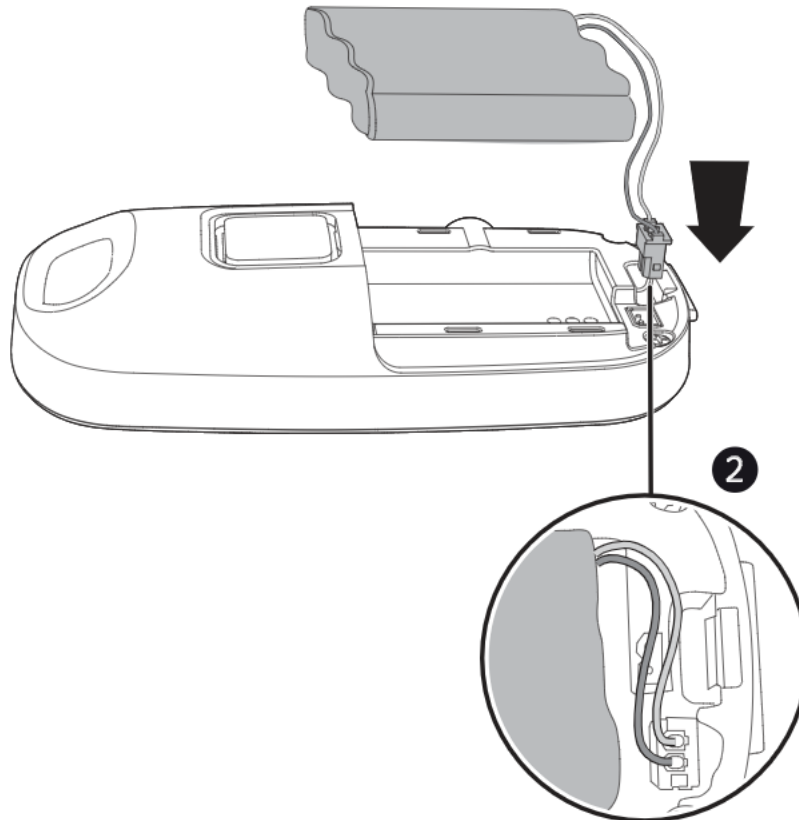

3. Align the battery compartment cover against the battery compartment.
4. Push the battery compartment cover down and click into place.

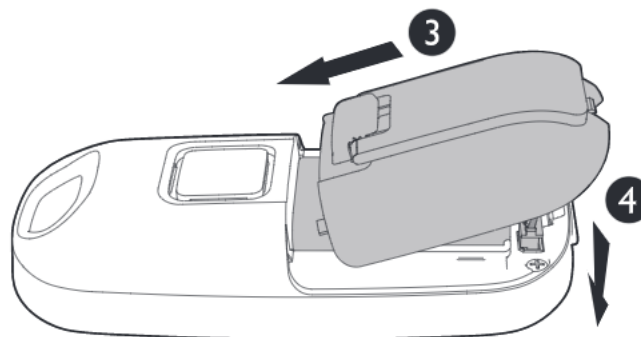

Getting started

Parent unit battery installation (continued)

note

- The operating time for using the rechargeable battery is short. If you want to monitor your baby for a long time, we recommend you connect the parent unit to AC power.
- If the parent unit will not be used for a long time, disconnect and remove the battery to prevent possible leakage.
- Use only the battery supplied with this product.

Getting started

Parent unit installation

Install the parent unit as shown below. Battery inside the parent unit will be charged when connected to power supply.

Bundle the power adapter cord neatly with a twist tie.

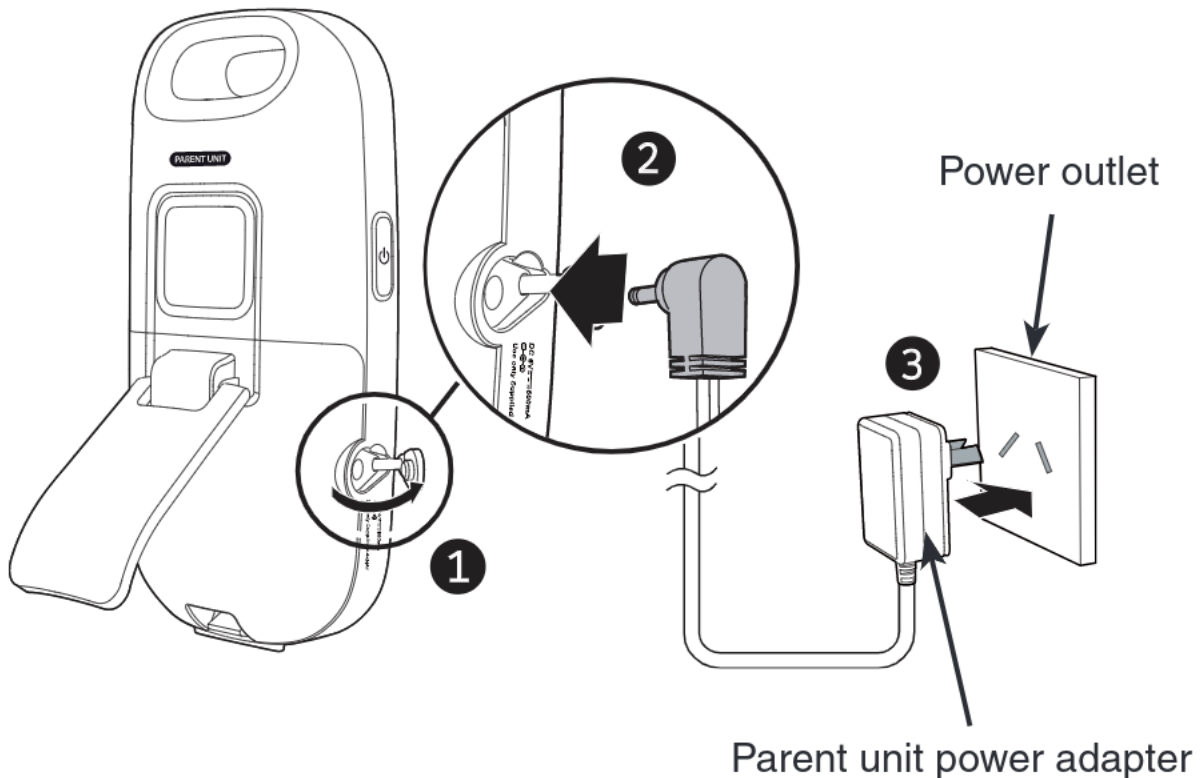



note

- Use only the parent unit power adapter supplied with this product. To order a replacement, contact VTech on 1 300 369 193.
- The parent unit power adapter is intended for a vertical or floor mount position. The prongs are not designed to hold the plug in place if it is plugged into a ceiling, under-the-table or cabinet outlet.
- Make sure the parent unit and the power adapter cord are out of reach of children.





Getting started

Parent unit battery charging

The parent unit turns on after you have installed the parent unit battery or connected the parent unit to AC power (see pages 5 to 8). The battery icon indicates the battery status (see the table below). The parent unit battery is fully charged after 12 hours of continuous charging.

When the parent unit is operating in battery mode and the battery is low, you need to charge the parent unit without interruption for at least 30 minutes to give the parent unit enough charge to use for a short time. When operating in low battery condition, the parent unit displays . The  light on the parent unit flashes and the parent unit plays short beeps to alert you.

The following table summarizes the battery charge indicators and actions to take.

Battery indicators	Battery status	Action
The battery icon is off and  displays.	No battery is installed but operates using AC power, or the battery has been installed incorrectly.	Install the parent unit battery. Charge without interruption (at least 30 minutes).
The screen displays  . The  light flashes.	The battery has very little charge and may be used for only a short time.	Charge without interruption (about 30 minutes).
The battery icon becomes solid  .	The battery is fully charged.	To keep the battery charged, connect it to AC power when not in use.

note

When you charge the battery pack initially or it is not used for a long period of time, charge it for 12 hours continuously. It takes longer to charge the battery when the parent unit is turned on. To shorten the charging time, turn the parent unit off.

Getting started

Baby unit overview

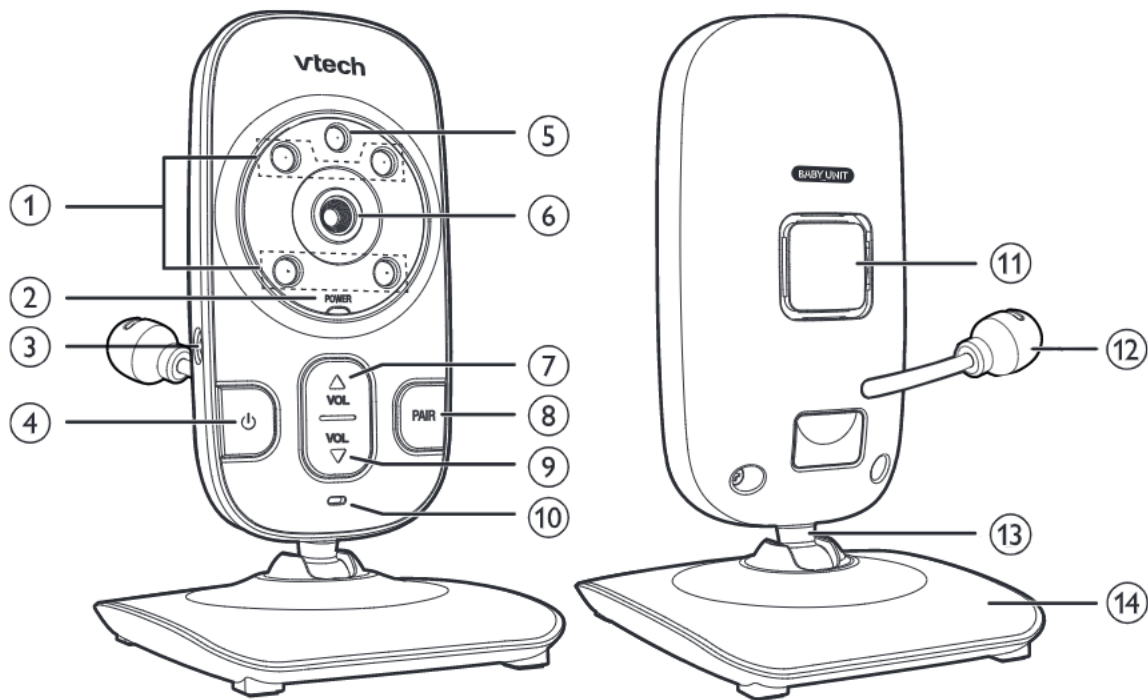

1. Infrared LEDs

Backup light for night vision.

2. POWER on/off indicator

- On when the baby unit is powered on and currently linked to parent unit.
- Flashes when the baby unit is not linked to a parent unit; or the pairing process is in progress; or the parent unit is not viewing this baby unit.

3. Power jack

4. (On/Off)

- Press and hold to power on.
- Press and hold again to power off.

5. Night sensor

Getting started

Baby unit overview (continued)

6. **Camera**
7. **▲/VOL**
Press to increase the listening volume.
8. **PAIR**
Press and hold to pair to the parent unit.
9. **▼/VOL**
Press to decrease the listening volume.
10. **Microphone**
11. **Speaker**
12. **Temperature sensor**
13. **Ball joint stand**
Pan or tilt to adjust the camera angle.
14. **Base**

Getting started

Parent unit overview

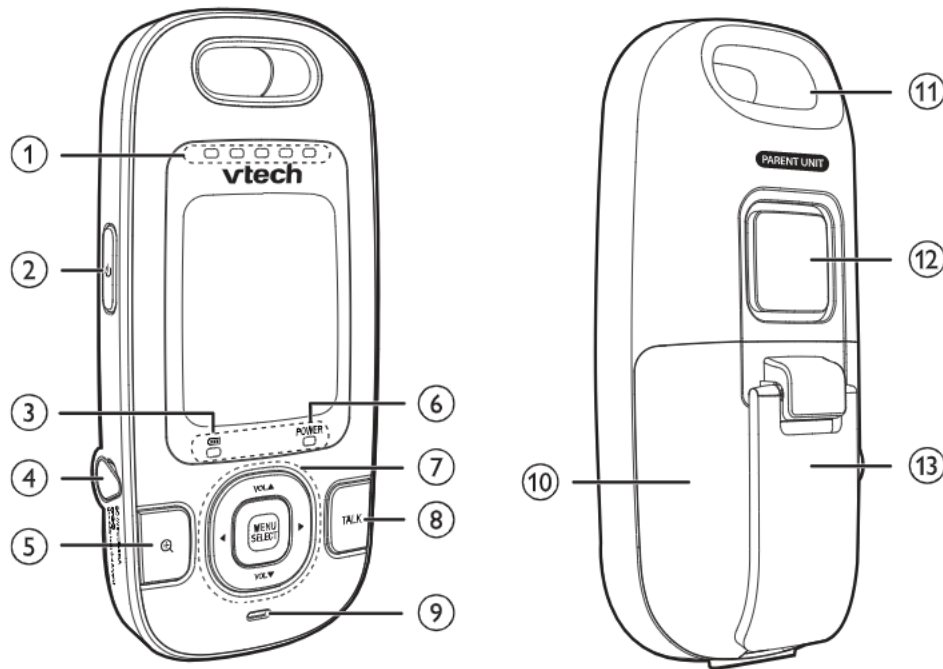

1. Visual sound indicator ○ ○ ○ ○ ○

The visual sound indicator has two functions. One is to show the sound level detected by the baby unit. The other one is to show the volume level during speaker volume setting.

Sound level detected by the baby unit

- ○ ○ ○ ○ ○ One to three green lights indicate a moderate sound level detected by the baby unit.
- ● ● ● ● ● Additional red lights indicate a higher sound level detected by the baby unit (e.g. baby crying loudly).

Speaker volume level

- ○ ○ ○ ○ ○ One to three green lights indicate **Level 1** to **Level 3** of the speaker volume setting.
- ● ● ● ● ● Additional red lights indicate **Level 4** to **Level 5** of the speaker volume setting.

Getting started

Parent unit overview (continued)

2. (On/off)

- Press to power on.
- Press and hold to power off.
- Press to turn on or off the screen.

3. **Battery level indicator**

- Light on when the parent unit battery is being charged.
- Light flashes when the parent unit battery is low and needs charging.
- Light off when the parent unit battery is fully charged, or when no battery is installed.

4. **Power jack**

5.

- While viewing image, press to zoom in/out.

6. **POWER on/off indicator**

- On when the parent unit is turned on.
- Flashes when in pairing process, or when connecting to baby unit while the baby unit is not available.

Getting started

Parent unit overview (continued)

7. Control key panel

MENU/SELECT

- Press to enter the menu.
- While in a menu, press to choose an item, or save a setting.

VOL▲

- Press to increase the speaker volume.
- While in the menu, press to scroll up.
- While viewing a zoomed image, press and hold to move the image upward.

VOL▼

- Press to decrease the speaker volume.
- While in the menu, press to scroll down.
- While viewing a zoomed image, press and hold to move the image downward.



- While in a menu, press to choose the option on the left side.
- While viewing a zoomed image, press and hold to move the image to the left.



- While in a menu, press to choose the option on the right side.
- While viewing a zoomed image, press and hold to move the image to the right.

Getting started

Parent unit overview (continued)

8. TALK

- While viewing image, press and hold to talk to the baby unit.

9. Microphone

10. Battery compartment cover













11. Slot for portable use

12. Speaker

13. Stand





Getting started

Parent unit display icons

	<p>Connection status</p> <ul style="list-style-type: none">-  displays when strong signal strength is detected between the baby unit and the parent unit.- ,  or  displays when moderate signal strength is detected between the baby unit and the parent unit.-  displays when the link between the baby unit and the parent unit is lost.-  displays when the parent unit is searching for the baby unit.
	<p>Current view status</p> <ul style="list-style-type: none">- Displays the baby unit that is being viewed.
	<p>Zoom</p> <ul style="list-style-type: none">- Displays when the camera at the baby unit has zoomed in.
	<p>Lullaby</p> <ul style="list-style-type: none">- Displays when the camera at the baby unit has zoomed in.
	<p>Volume off</p> <ul style="list-style-type: none">- Displays when the volume is turned off.
	<p>Sound activation</p> <ul style="list-style-type: none">- Displays when the sound activation is on.















Getting started

Parent unit display icons (continued)

20 °C	Real-time temperature - Displays the real-time temperature of the baby unit.
	Battery status -  animates when the battery is charging. -  displays solid when the battery is fully charged. -  displays when the battery is low and needs charging. -  displays when no battery is installed but operates using AC power, or the battery has been installed incorrectly.



Getting started

Parent unit main menu icons

	<p>Brightness</p> <ul style="list-style-type: none">You can change the brightness of the screen. The LCD brightness is preset to  ■■■■. ■■■■ - brightest screen display. ■■■■ - brighter screen display. ■■■ - average screen brightness. ■■ - darker screen display. ■ - darkest screen display.
	<p>Sensitivity</p> <ul style="list-style-type: none">With this feature, you can choose to hear sounds from the baby unit all the time, or to hear sounds that exceed a certain level. You can use the parent unit to adjust the microphone sensitivity of your baby unit. The higher the sensitivity level, the more sensitive the baby unit is in detecting sounds for transmitting to the parent unit. The sound sensitivity is preset to  ■■■■. ■■■■ - high sensitivity level. ■■■■ - medium high sensitivity level. ■■■ - medium sensitivity level. ■■ - medium low sensitivity level. ■ - low sensitivity level.
	<p>Sound activation</p> <ul style="list-style-type: none">Automatically turns on the parent unit screen when a sound is detected in your baby's room. When no sound is detected, the screen is off to save power.✓ - turn on sound activation.✗ - turn off sound activation.

Getting started

Parent unit main menu icons (continued)

	<p>Lullaby control</p> <ul style="list-style-type: none">• You can select from a total of 5 lullabies to play, or play all lullabies.
	<p>Temperture</p> <ul style="list-style-type: none">• You can set the temperature format of the baby unit.
	<p>Pairing</p> <ul style="list-style-type: none">• The baby unit and parent unit provided are already paired.

Getting started

Positioning the baby monitor

note

This baby monitor is intended as an aid. It is not a substitute for proper adult supervision, and should not be used as such.



Keep the baby unit out of the reach of the baby. Never place or mount the baby unit inside the baby's cot or playpen.

1. Place the baby unit at least 1 metre away from your baby.

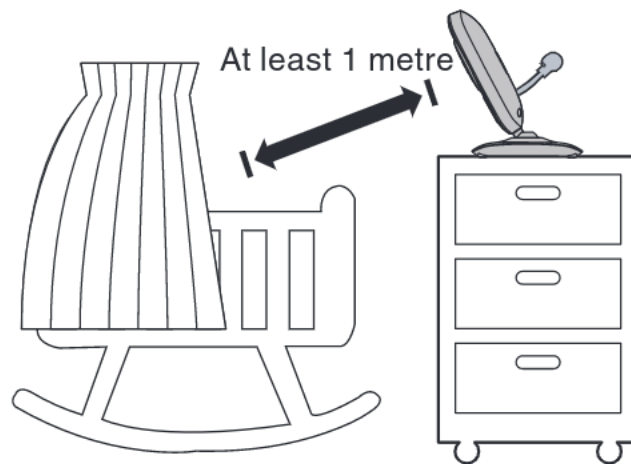

note

If you experience audio feedback on either the parent unit or baby unit, move the parent unit further away until there is no more audio feedback; or press VOL▼ on the parent unit to lower the audio feedback sound.

2. Place the parent unit at least 1 metre away from the baby unit.

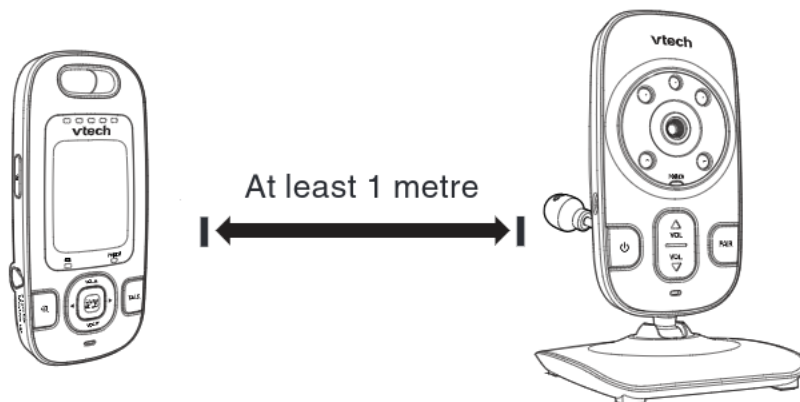

You can increase the speaker volume of the parent unit if you cannot hear the sounds transmitted from the baby unit.

Getting started

Operating range

The operating range of the baby monitor is up to 300 metres outdoors or 50 metres indoors. The actual operating range may vary depending on the environmental conditions, and other interferences such as walls, doors, and other obstructions.

Audio settings

The baby unit may not detect sounds when the sensitivity level is set below a certain level. You may need to increase the sensitivity level (see pages 24 and 25).

You may need to turn the speaker volume louder on the parent unit to hear the sounds transmitted from the baby unit (see page 22).



note

It is the caregiver's responsibility to stay close enough to take care of any eventuality.



Test your baby monitor before use

You may test the baby monitor before initial use, and at regular times thereafter.

To test your baby monitor:



1. Place the parent unit and the baby unit in the same room to test the product. Make sure the baby unit are at least 1 metre away from the parent unit.
2. Press and hold  to turn on the baby unit. The **POWER** light turns on.
3. Press  to turn on the parent unit. The screen turns on.

note



If both units are not connected, the parent unit displays  while searching for the baby unit. If no baby unit is found after a while, it displays .

Using your baby monitor

Power on or off the baby unit

- Press and hold  to power on the baby unit. The **POWER** light turns on.
- Press and hold  again to turn off the baby unit. The **POWER** light turns off.

Power on or off the parent unit

- Press  to power on the parent unit. The screen turns on.
- Press and hold  again to power off the parent unit. The screen turns off.

Turn on or off the parent unit screen

You can turn on or off the parent unit screen without powering off the parent unit. You can still hear sound from the baby unit.



- Press  on the parent unit at any time.

Adjust the speaker volume for baby unit

You can adjust the speaker volume.

- Press **▲/VOL** or **▼/VOL** on the baby unit at any time.

Adjust the speaker volume for parent unit

You can adjust the speaker volume from  to , or turn it off. The preset speaker volume is .

- Press **VOL▲** or **VOL▼** on the parent unit while viewing image from baby unit.

When the speaker volume is set to off, the screen displays .

Using your baby monitor

Adjust the LCD brightness of the parent unit

You can adjust the brightness of the parent unit screen. The LCD brightness is preset to  ■■■■.







1. Press **MENU/SELECT** when the parent unit is not in use.
2. Press ▼ or ▲ to scroll to .
3. Press ◀ or ▶ to adjust the brightness.
4. Press **MENU/SELECT** to confirm your selection.

Using your baby monitor

Adjust the sound sensitivity of the baby unit

You can choose to hear sounds from the baby unit all the time, or to hear sounds that exceed a certain level. You can use the parent unit to adjust the microphone sensitivity of your baby unit. The higher the sensitivity level, the more sensitive the baby unit is in detecting sounds for transmitting to the parent unit. The sound sensitivity is preset to .

Sound sensitivity table for reference

Icon display	Sensitivity	Description
	 <p>High sensitivity</p> <p>Low sensitivity</p>	<p>High sensitivity level The parent unit speaker is constantly on, and you will hear all sounds (including background noises) from your baby's room.</p>
		<p>Medium high sensitivity level The parent unit speaker turns on for soft babbling and louder sounds from your baby. It remains quiet when your baby sleeps soundly.</p>
		<p>Medium sensitivity level The parent unit speaker turns on for loud babbling and louder sounds from your baby. It remains quiet when your baby makes soft sounds.</p>
		<p>Medium low sensitivity level The parent unit speaker turns on for crying and louder sounds from your baby. It remains quiet when your baby makes soft sounds.</p>
		<p>Low sensitivity level The parent unit speaker turns on for loud crying or screeching sounds from your baby. It remains quiet when your baby makes soft sounds.</p>

Using your baby monitor

Adjust the sound sensitivity of the baby unit (continued)



1. Press **MENU/SELECT** when the parent unit is not in use.
2. Press **VOL▼** or **VOL▲** to scroll to .
3. Press **◀** or **▶** to adjust the sensitivity level.
4. Press **MENU/SELECT** to confirm your selection.





You can adjust the baby unit placement to improve the sound detection.

Turn on or off the sound activation

The parent unit continuously monitors the sound level in your baby's room. When the sound activation mode is on, the parent unit screen turns on when the baby unit detects a sound. As long as no sound is detected within 50 seconds, the parent unit screen is off to save power. When your baby starts to cry, the sound activation triggers the parent unit screen automatically turns on.

1. Press **MENU/SELECT** when the parent unit is not in use.
2. Press **VOL▼** or **VOL▲** to scroll to .
3. Press **◀** or **▶** to select  to turn on, or  to turn off sound activation.
4. Press **MENU/SELECT** to confirm your selection.



note

- If you mute the speaker while sound activation is on, then you hear a beep sound whenever the screen turns on.
- If you want to turn on the parent unit screen continuously while the sound activation is on, then set the sound sensitivity to  .

Using your baby monitor

Lullaby control on the parent unit

There are 5 lullabies to choose from, and the chosen lullaby plays repeatedly for approximately 20 minutes. You can choose a lullaby to play to comfort your baby.

1. Press **MENU/SELECT** when the parent unit is not in use.
2. Press ▼ or ▲ to scroll to .
3. Press ◀ or ▶ to choose the desired lullaby to play (1 to 5),  to play all, or **II** to stop playing lullaby.
4. Press **MENU/SELECT** to confirm your selection.

note

If you select  to play all, lullabies will be played in the sequence from 1 to 5 and in cyclic.



Temperature format

You can set the temperature format to be displayed on the parent unit

1. Press **MENU/SELECT** when the parent unit is not in use.
2. Press ▼ or ▲ to scroll to .
3. Press ◀ or ▶ to choose °C or °F
4. Press **MENU/SELECT** to confirm your selection.

Zoom

You can zoom in or out while viewing image from baby unit.

- Press  to zoom in.
- Press and hold **VOL▲**, **VOL▼**, ◀ or ▶ to move the zoomed image upward, downward, to the left or to the right correspondingly.
- Press  again to zoom out.

Using your baby monitor

Talk function

You can use the **TALK** function of the parent unit to talk to and comfort your baby.

- Press and hold **TALK** when the parent unit is viewing the baby unit. Speak towards the microphone on the parent unit. Your voice is broadcast to the baby unit.

Night vision

The baby unit has infrared LEDs that allow you to see your baby clearly at night or in a dark room. When the baby unit detects low light levels, the infrared LEDs are switched on automatically.



When the infrared LEDs are on, the image is in black and white. This is normal due to external light sources.



Depending on the surroundings and other interfering factors, like lightings, objects, colors and backgrounds, the display resolution may vary. Adjust the baby unit's angle or place the baby unit at a higher level to prevent glare and blurry display.

Portable use of parent unit

note

Sling is not included. You may need to buy a sling for portable usage.

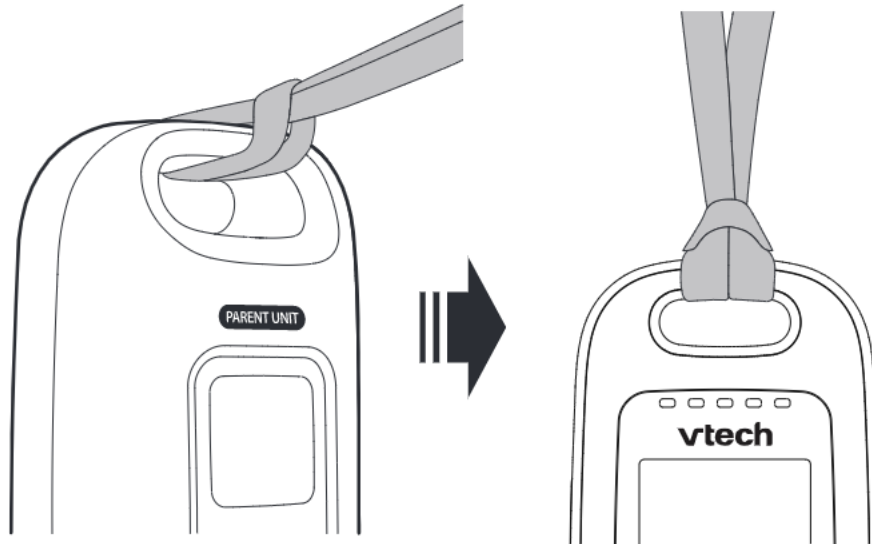

1. Make sure battery is installed and charged. Unplug the power adaptor.
2. Pinch the end of the sling and insert it into the slot on the top of the parent unit.
3. Insert the one end of the sling into the other end of the sling, and fasten it.

Appendix

CAUTION:

To reduce the risk of fire or injury, read and follow these instructions:

- Use only the battery provided or equivalent. To order a replacement, contact VTech on 1 300 369 193.
- Do not dispose of the battery pack in a fire. Check with local waste management codes for special disposal instructions.
- Do not open or mutilate the battery pack. Released electrolyte is corrosive and may cause burns or injury to the eyes or skin. The electrolyte may be toxic if swallowed.
- Exercise care in handling the battery pack in order not to create a short circuit with conductive materials.
- Charge the battery pack provided with or identified for use with this product only in accordance with the instructions and limitations specified in this user's manual.
- Observe proper polarity orientation between the battery and metallic contacts.
- To prevent fire or shock hazard, do not expose this product to water or any type of moisture.

Appendix

Troubleshooting

If you have difficulty with this product, please try the suggestions below. For customer service, contact VTech on 1 300 369 193.

My video and audio monitor does not work at all.

- Make sure the baby unit and the parent units are installed correctly (pages 2 to 8).
- Make sure the parent unit battery pack is installed (pages 5 to 7) and charged correctly (page 9). For optimum daily performance, charge the parent unit when it is not in use.
- Make sure the power adapters are securely plugged into the power outlet.
- Make sure the power adapter cords are plugged firmly into the baby unit and parent unit.
- Make sure the baby unit and the parent unit are turned on.
- The parent unit may be too far away from the baby unit. Move the parent unit closer to the baby unit (but not less than 1 metre).
- Unplug the electrical power to the baby unit and parent unit. Wait for approximately 15 seconds, then plug it back in. Turn on the baby unit and the parent unit. Allow up to one minute for the baby unit and the parent unit to synchronize.
- Charge the battery in the parent unit for up to 12 hours.
- If the battery is completely depleted, it may take up to 30 minutes to charge the parent unit before it can be used for a very short time (page 9).
- Remove and install the battery again. If that still does not work, it may be necessary to purchase a new battery.
- Large obstructions may impact the reception. Try to relocate the baby unit, away from large obstructions such as walls and doors.
- Other electronic products may cause interference with your video and audio monitor. Try installing your video and audio monitor as far away from these electronic devices as possible: wireless routers, radios, cellular telephones, intercoms, room monitors, televisions, personal computers, kitchen appliances and cordless telephones.

Appendix

Troubleshooting (continued)

The video and audio monitor produces high-pitched noise.

- The parent unit may be too close to the baby unit or another parent unit. Make sure the parent units and the baby unit are at least 1 metre away from one another.
- You may be too close to the baby unit or another parent unit when you press and hold **TALK**. Make sure the parent units and the baby unit are at least 1 metre away from one another.
- You may have set the sensitivity level too high. You may need to adjust the sensitivity level to a lower level to avoid audio feedback (pages 24 and 25).

My parent unit plays any sounds from the baby unit and I think it is too noisy.

- You may have set the sensitivity level to the highest level (🔊 ■■■■■). If you do so, the baby unit will transmit any sounds detected to the parent units. You may need to adjust the sensitivity level to a lower level (pages 24 and 25).
- You may need to adjust the speaker volume on the parent unit (page 22).

My parent unit does not play any sound when there is noise from the baby unit.

- Make sure the parent unit is powered up by connecting it to AC power (page 8) or to the rechargeable battery pack provided (page 5).
- Make sure the power adapter and the parent unit are plugged in correctly and securely (page 8).
- Make sure the parent unit is turned on (22) and the speaker volume is not set to off (page 22).
- The parent unit may be too far away from the baby unit. Move the parent unit closer to the baby unit (but not less than 1 metre).
- If the parent unit is powered by the provided battery pack, make sure there is sufficient charge. Charge the battery in the parent unit for up to 12 hours.

Appendix



Troubleshooting (continued)

- You may have set the sensitivity level to a very low level. If you do so, the baby unit will not detect sounds that is too soft or light. You may need to adjust the sensitivity level to a higher level (pages 24 and 25).
- Large obstructions may impact the reception. Try to relocate the baby unit, away from large obstructions such as walls and doors.
- Remove and install the battery again. Turn on the baby unit and the parent unit. Allow up to one minute for the parent unit and the baby unit to synchronize.
- Other electronic products may cause interference with your video and audio monitor. Try installing your video and audio monitor as far away from these electronic devices as possible: wireless routers, radios, cellular telephones, intercoms, room monitors, televisions, personal computers, kitchen appliances and cordless telephones.

The light flashes on the parent unit.

- Charge the battery in the parent unit for up to 12 hours.
- Completely remove and install the battery again and use it until fully depleted, then recharge the battery in the parent unit for up to 12 hours.
- If the above measures do not correct the problem, replace the battery.

The battery does not charge in the parent unit or the parent unit battery does not accept charge.

- Make sure the battery is installed in the parent unit battery compartment correctly. The  light on the parent unit should be on.
- Completely remove and install the battery again, then charge for up to 12 hours.
- If  light on the parent unit is not on, refer to **The  light on the parent unit is off** below.
- If the battery is completely depleted, it may take up to 30 minutes to charge the parent unit before it can be used for a very short time (page 9).
- Purchase a new battery. Refer to **Parent unit battery installation** (page 5) and **Parent unit battery charging** (page 9).

Appendix

Troubleshooting (continued)

The light on the parent unit is off.

- Make sure the parent unit battery is installed (page 5) and charged (page 9) correctly.
- Make sure the power adapter and the parent unit are plugged in correctly and securely.
- Unplug the parent unit power adapter. Wait for 15 seconds before plugging it back in. Allow up to one minute for the baby unit and parent unit to reset.

The parent unit beeps and is not performing normally.

- Make sure the baby unit is turned on.
- Move the parent unit closer to the baby unit (but not less than 1 metre). The parent unit may be out of range.
- If the parent unit is powered by the provided battery pack, it may not have enough charge for the parent unit to perform normally. Charge the battery in the parent unit for up to 12 hours.
- Reset the parent units and the baby unit by turning them off and unplugging the electrical power to the parent units and the baby unit. Wait for 15 seconds and plug them back in again. Turn on the parent units and the baby unit. Allow up to one minute for the parent unit and the baby unit to synchronize.
- Other electronic products such as HAM radios and DECT cordless phones can cause interference with your video and audio monitor. Try installing your video and audio monitor as far away as possible from these types of electronic devices.

The link between the baby unit and the parent unit is lost every now and then, and I'm experiencing sound interruptions.

- Move the parent unit closer to the baby unit (but not less than 1 metre). The parent unit may be out of range.
- Reset the baby unit by unplugging the electrical power to the baby unit. Wait for 15 seconds and plug it back in again. Turn on the baby unit and the parent unit. Allow up to one minute for the parent unit and the baby unit to synchronize.

Appendix

Troubleshooting (continued)

Common cure for electronic equipment.

- If the video and audio monitor is not responding normally, try the following (in the order listed):
 1. Disconnect the power to the baby unit and the parent units.
 2. Remove the battery packs in the parent units and then install again.
 3. Wait a few minutes before connecting power back to the baby unit and the parent units.
 4. The baby unit and the parent units should turn on when they are powered up.
 5. Wait for the parent units to synchronize with the baby unit. Allow up to one minute for this to take place.

Appendix

Operating range

The baby unit and the parent unit can communicate over only a certain distance - which can vary with the locations of the baby unit, the parent unit, the weather, and the layout of your home.

When the parent unit is out of range, the parent unit beeps and displays .

To improve reception, move closer to the baby unit (but not less than 1 metre).

Maintenance

Taking care of your video and audio monitor

Your video and audio monitor contains sophisticated electronic parts, so it must be treated with care.

Avoid rough treatment

Place the baby unit and parent unit down gently. Save the original packing materials to protect your video and audio monitor if you ever need to ship it.

Avoid water

Your video and audio monitor can be damaged if it gets wet. Do not use the parent unit and/or baby unit outdoors in the rain, or handle it with wet hands. Do not install the video and audio monitor near a sink, bathtub or shower.

Electrical storms

Electrical storms can sometimes cause power surges harmful to electronic equipment. For your own safety, take caution when using electrical appliances during storms.

Cleaning your video and audio monitor

Your video and audio monitor has a durable plastic casing that should retain its luster for many years. Clean it only with a soft cloth slightly dampened with water or mild soap. Do not use excess water or cleaning solvents of any kind.

Remember that electrical appliances can cause serious injury if used when you are wet or standing in water. If the baby unit and/or parent units should fall into water, DO NOT RETRIEVE IT UNTIL YOU UNPLUG THE POWER CORDS FROM THE WALL. Then pull the units out by the unplugged cords.

Appendix

Customer service and product warranty

IMPORTANT

Please retain this booklet with your sales receipt as proof of the date of purchase.

Customer Service

If you require assistance in operating this product, please call the TechHelp Information Line on 1300 369 193 or contact VTech by e-mail at: tcpsupport_au@vtech.com.

Voluntary Product Warranty

In addition to your Statutory Rights and subject to the conditions below, VTech warrants that this product will be free from any defect in materials or workmanship under conditions of normal use for a period of 24 months from date of purchase.

VTech does not warrant that the product will be free from defects if defects are caused by an accident, misuse, abuse, improper installation or operation, vermin infestations, lack of reasonable care, unauthorised modification, loss of parts, tampering or attempted repair by a person not authorised by VTech; or where the product has been damaged by lightning or a mains power surge. To make a claim under this Voluntary Product Warranty you must call the TechHelp Information Line on 1300 369 193 or contact VTech by e-mail at: tcpsupport_au@vtech.com where a Customer Service Representative will inform you of the product return process. You will need to ensure that:

- You provide proof of purchase;
- Your product is suitably packaged (original packaging is not required); and
- You have included all components from the original purchase.

For your records

Date of purchase:

Place of purchase:

Serial number:

Appendix

Customer service and product warranty (continued)

For Voluntary Product Warranty purposes, proof of purchase is required so please keep your receipt.

The benefits conferred by this Voluntary Product Warranty are in addition to other rights and remedies that are available to you under law, which cannot be excluded. The processes for this Voluntary Product Warranty in no way limit your rights which arise as a result of your Statutory Rights.

This Voluntary Product Warranty is given by:

VTech Telecommunications (Australia) Pty Ltd ABN 70 136 672 627
Address: 24 Gilby Road, Mount Waverley 3149

IMPORTANT NOTE: THIS IS NOT A PRODUCT RETURN OR SERVICE ADDRESS – PLEASE CONTACT TECHHELP BY PHONE OR EMAIL FOR PRODUCT AND WARRANTY SUPPORT. NO LIABILITY WILL BE ACCEPTED BY VTECH FOR PRODUCTS RETURNED TO THIS ADDRESS UNDER THIS VOLUNTARY PRODUCT WARRANTY.

Phone number: 1300 369 193

Email address: tcpsupport_au@vtech.com

Statutory Rights

Our goods come with guarantees that cannot be excluded under the Australian Consumer Law. You are entitled to a replacement or refund for a major failure and compensation for any other reasonably foreseeable loss or damage. You are also entitled to have the goods repaired or replaced if the goods fail to be of acceptable quality and the failure does not amount to a major failure.

Appendix

Technical specifications

Frequency control	Crystal controlled PLL synthesizer
-------------------	------------------------------------

Transmit frequency	Baby unit: 2407.5 - 2475 MHz Parent unit: 2407.5 - 2475 MHz
--------------------	--

Channels	21
----------	----

LCD	2" Color LCD (TFT 176x220 pixel)
-----	-------------------------------------

Nominal effective range	Actual operating range may vary according to environmental conditions at the time of use.
-------------------------	---

Power requirement	Use only power adaptor listed below: Baby unit: Tenpao S003IS0600060 Input: 100-240V AC 150mA 50/60Hz Output: 6V DC 600mA Parent unit: Tenpao S003IS0600060 Input: 100-240V AC 150mA 50/60Hz Output: 6V DC 600mA For pluggable equipment, the socket-outlet (power adaptor) shall be installed near the equipment and shall be easily accessible Use only battery listed below: Parent Unit: Corun NI-MH-44AAA900*3-B 3 x 1.2V AAA size 900mAh NiMH GPI VTRHCH93N002 3 x 1.2V AAA size 900mAh NiMH
-------------------	---

Index

A

Adjust baby unit angle 3
Audio settings 21

B

Baby unit installation 2-4
Baby unit overview 10-11
Battery installation 5-7
Battery charging 9
Brightness 23

C

Cautions v
Charging 9

D

Display screen icons 16

I

Important safety
instructions iii-iv
Installation 2-8

L

LCD brightness 23
Limited warranty 36-37

M

Main menu icons 18-19
Maintenance 35

N

Night vision 28

O

Operating range 21, 35
Operation 22
Overview 10-15

P

Parent unit battery charging 9
Parent unit battery
installation 5-7
Parent unit display
screen icons 16
Parent unit main menu icons 18
Parent unit installation 8
Parent unit operation 22
Parent unit overview 12
Parts checklist 1
Portable use of parent unit 28
Position for the audio
baby monitor 20
Power off the baby unit 22
Power off the parent unit 22
Power on the baby unit 22
Power on the parent unit 22

R

Range 21, 35

Index

S

Safety instructions iii-iv

Screen icons 16

Sound activation 25

Sound sensitivity 24

Speaker volume 22

T

Talk to the baby unit 27

Technical specifications 38

Test your baby monitor 21

Troubleshooting 30-34

Turn off the baby unit 22

Turn off the parent unit 22

Turn on the baby unit 22

Turn on the parent unit 22

V

Volume 22

W

Warranty 36-37

Z

Zoom 26



VTech is the registered trademark of VTech Holdings Limited.
Copyright © 2015 for VTECH TELECOMMUNICATIONS LTD.

All rights reserved. Printed in China.

Version A

vtech[®]