

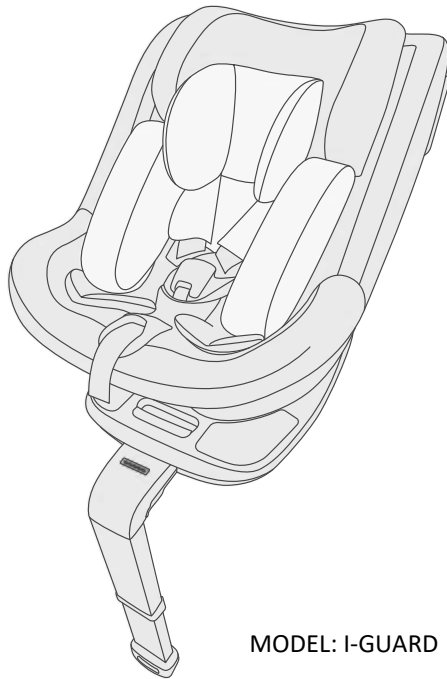

# **I-GUARD**

## **USER GUIDE**



MODEL: I-GUARD ECE R129.03 v.1.2

ATTENTION! Product graphics are only illustrative.

### A.1

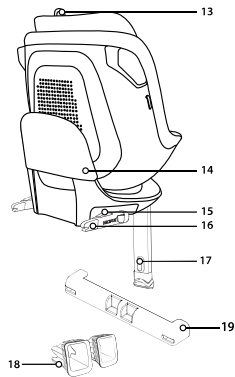
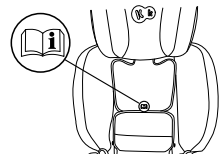
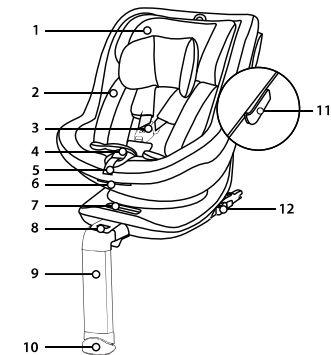

Please read this user manual carefully before using your child's car seat for the first time. It is your responsibility to ensure your child's safety and failure to read this manual may affect it.

## 1.0 Car seat elements

1. Headrest
2. Baby insert
3. 5-point seat belt buckle
4. 5-point seat belt adjustment button
5. Adjustment belt
6. Seat recline lever
7. Seat rotation lever with indicator
8. Leg extension indicator
9. Support leg
10. Footrest with indicator
11. Interior belt holders
12. ISOFIX sliding lever
13. Head restraint adjustment lever
14. Anti-rotation frame
15. Release button with ISOFIX status indicator
16. ISOFIX attachments
17. Height adjustment button for the support leg
18. ISOFIX guides
19. ISOFIX attachment cover

(rys.A.14)

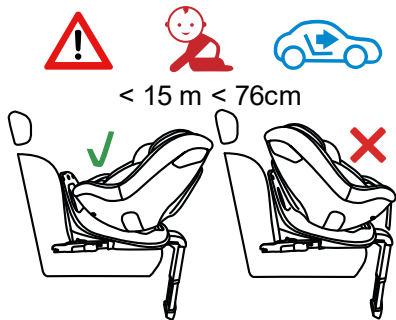

## 2.0 Usage

The car seat was designed, tested and approved according to the requirements of UN/ECE Regulation No. 129 concerning the approval of child restraint systems (UN/ECE R129/03). The I-GUARD car seat is designed for the transport of children between 40 and 105 cm (up to approximately 4 years old).

The seat must be installed in the vehicle using the ISOFIX attachments and a support leg. This car seat can only be installed on vehicle seats that have been approved for the use of child restraint systems in accordance with the vehicle handbook. The child in the seat is secured using the 5-point seat belt. CAUTION: Before every journey, make sure that the 5-point seat belts are correctly adjusted and firmly fastened to the child's body. The safety harness must never be twisted!

Do not position the seat forward-facing until the child is 15 months old and 76 cm tall.

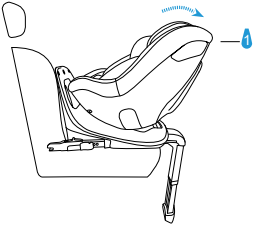
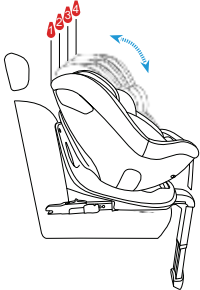
Seat mountings	Seat orientation	Seat position	Size of the child
ISOFIX + support leg	rearward-facing		<p>40cm–105cm 0 months – approx. 4 years</p>
ISOFIX + support leg	forward-facing		<p>76cm–105cm &gt; 15months – approx. 4 years</p>

### 3.0 Safety instructions

Please take a few minutes to read this user manual to ensure your child's safety. Many avoidable injuries are caused by reckless and improper use of the seat.

NOTE: It is always good to have the manual within reach. We advise you to keep it in a designated place on the inside of the seat under the backrest cover.

- The seat is only suitable for installation on forward-facing car seats. The seat must not be installed on rearward or side-facing seats. The seat must always be secured using the ISOFIX attachment with the support leg.
- DO NOT place a child restraint on seats with active front airbags as this can be dangerous. This does not apply to side airbags.
- If installed on the front seat, the front airbag must be deactivated. It is recommended to install the child seat only on the rear seats of the vehicle. For guidance on the suitability of a vehicle seat for use with a child restraint system, refer to the vehicle handbook.
- Before every journey, make sure that the 5-point seat belts are correctly adjusted and firmly fastened to the child's body.

Under no circumstances must the safety harness be twisted!

- **REMEMBER, THE CLOSER THE BELT IS TO THE CHILD'S BODY, THE GREATER THE LEVEL OF SAFETY. THEREFORE, DO NOT WEAR THICK CLOTHING UNDER THE BELT.**
- The lap belts of the seat belt must run as low as possible across your child's groin to ensure an optimum effect in the event of an accident.
- Only an optimally adjusted head restraint can give your child maximum protection and comfort while ensuring that the shoulder straps fit properly.
- The seat should be replaced if it has been subjected to sudden stresses during a traffic accident.
- The car seat must not be modified in any way without the approval of the relevant approval authority. Failure to install the seat in accordance with the instructions supplied by the manufacturer may lead to risks to life and health.
- Keep your child's car seat out of direct sunlight, otherwise the heated parts could burn your child. Protect your child and the car seat from the sun's rays.
- Never leave your child unattended in a child seat.
- Ensure that luggage and other objects are sufficiently secured, particularly on the shelf under the rear window, as they could cause injury in the event of a collision.

- The seat cannot be used without the cover.
  - The infant insert serves to protect the baby and must be used until the baby reaches a height of 60 cm.
  - Do not use a replacement cover other than the one recommended by the manufacturer as it is an integral part of the seat's safety system.
  - We recommend that you keep the instruction manual for the seat as long as it is in use.
  - Do not use attachment points other than those described in the instructions and marked on the seat.
  - All hard components and plastic parts of the child seat must be positioned and installed in such a way that they cannot be trapped by the vehicle's sliding seat or doors under normal conditions of use.
  - Inspect the seat regularly, paying particular attention to the attachment points, seams and adjusting devices. Make sure that all mechanical parts are fully functional. Never grease or oil any part of the child seat. Stop using the seat if parts are damaged or loose.
  - In the event of an emergency, it is important to release the seat belts quickly. This means that the 5-point harness release button is not fully secured, ensure that your child does not play with the 5-point harness buckle.
- Set a good example for your child and always wear a seat belt. An adult who is not wearing a seat belt can also pose a risk to a child.
  - Before every car journey, make sure that the seat is correctly positioned.
  - The seat must also be secured when not in use. An unsecured child seat can cause injury to passengers even in emergency braking.
  - Always ensure that the car seat does not become jammed on any surface when closing the vehicle door or adjusting the rear seat.
  - For some vehicle seats made of delicate materials, using the car seat can leave marks or cause discolouration. To prevent this, you can place a blanket, towel or similar product under the car seat.

A.2

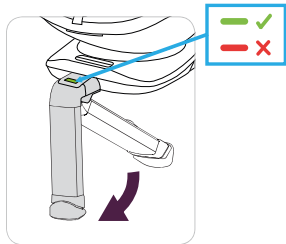

A.3a

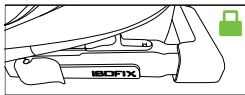

A.3b

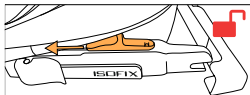

A.4

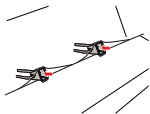

## 4.0 In-vehicle installation

In the event of sudden braking or an accident, persons not wearing seat belts may cause injury to other passengers.

Always check that:

- The seatbacks in the vehicle are locked (i.e. the rear seat folding backrest lock is engaged).
- All heavy objects and those with sharp edges are secured (e.g. on the rear shelf).
- All passengers have fastened their seat belts.
- The seat is always secured, even if the child is not being carried in it.

### 4.1 Rearward-facing installation for children from 40 to 105 cm (0 to approx. 4) using the ISOFIX attachment system with a support leg.

IMPORTANT! The location of the ISOFIX attachment points and other necessary information for installing the seat in the vehicle is given in the vehicle handbook. The user MUST also read the manual from the vehicle.

- Before positioning the seat in the car, we recommend unfolding the support leg (9) (fig. A.2).
- The cover (19) on the ISOFIX attachments (16) (if not already removed) must be removed from the seat, for this purpose push the ISOFIX release button (15), and the system will release the cover, which must be removed (fig. A.3a, A.3b).

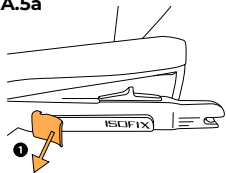
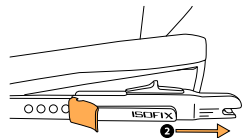
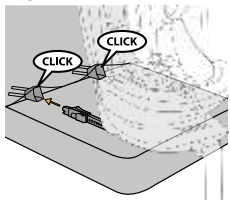
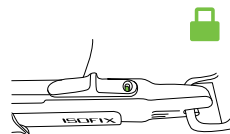
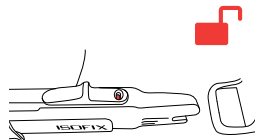
**A.5a****A.5b****A.6****A.7a****A.7b**

- Place the seat without the cover (19) with the folded-out support leg on the vehicle seat.
  - Attach the ISOFIX guides (18) to the car seat connectors (A.4).
  - Slide the ISOFIX attachments (16) to their maximum length by unlocking and holding the sliding lever (12) (fig. A.5a) and then sliding the attachments (fig. A.5b). This has to be done on both sides of the seat.
  - Connect the extended ISOFIX attachments (16) to the ISOFIX guides (18) installed in the car seat until a characteristic click occurs (figure A.6). After the correct installation of the ISOFIX attachments, the indicator on the button (15) will change from red to green; verify the correct installation with green indicators (fig. A.7a, A.7b).
- ATTENTION! The locking clips are only correctly fastened when both button markers are completely green.



A.8

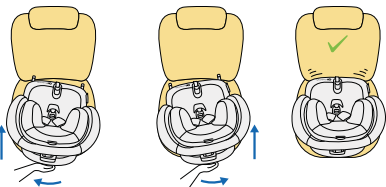

A.9



A.10a

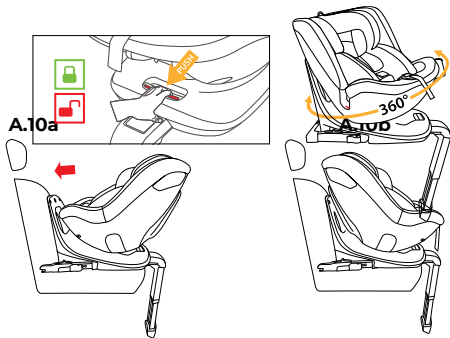

- Push the base with a left-right movement towards the backrest of the vehicle seat until it is completely aligned with the backrest of the anti-rotation frame (14) (fig. A.8)
  - When the seat is correctly installed with ISOFIX, position the seat rearward facing. Push the seat rotation lever (7) (fig. A.9) to turn the seat rearward (fig. A.10a), a correctly locked position will be indicated by the green colour indicator at the seat rotation lever (7).
  - Make sure the base is fixed by trying to pull it out of the ISOFIX attachment points.
  - When the seat is correctly installed with the ISOFIX attachments and the base's anti-rotation frame is fully seated against the backrest of the seat, proceed to adjust the support leg (9).
- ATTENTION: Before adjusting the support leg make sure the support leg extension indicator is green (8).
- Only after this has been done should the height of the support leg be adjusted.

A.11

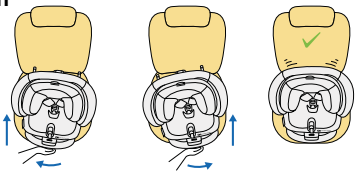

A.12

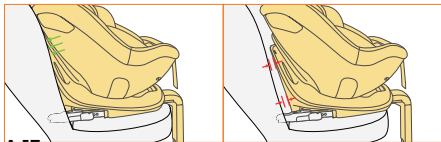

A.13

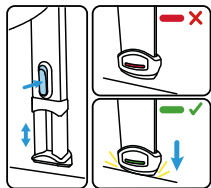

- By holding down the leg height adjustment button (17), you will release the leg height lock and the leg should automatically extend. Adjust the leg height so that the foot meets resistance with the vehicle's ground; now you can release the button. If after the leg height lock the foot indicator (10) turns green, it means that the installation is correct (fig. A.13) otherwise repeat the adjustment of the support leg height.

**ATTENTION! Never mount the foot of the support leg on the glove box on the floor of the vehicle, there is a risk of the glove box collapsing during an accident, if in doubt consult the vehicle handbook.**

**ATTENTION: The support leg must never hang in the air and no objects may be placed under it.**

**IMPORTANT:** Make sure the support leg is supporting and not raising the bottom of the I-GUARD seat above the plane of the car seat.

- Take hold of the seat and check that it is securely fastened without slack. All ISOFIX attachments and support leg indicators should display green. If not, repeat the previous installation steps.

**NOTE:** Make sure the seat position is well established and stable. Check the indicators on the ISOFIX attachment and the support leg.

## 4.2 Forward-facing seat installation for children between 76 and 105 cm using the ISOFIX attachment system with a support leg.

IMPORTANT! The location of the ISOFIX attachment points and other necessary information for installing the seat in the vehicle is given in the vehicle handbook. The user MUST also read the manual from the vehicle.

- Before positioning the seat in the car, we recommend unfolding the support leg (9) (fig. A.2).
- The cover (19) on the ISOFIX attachments (16) (if not already removed) must be removed from the seat, for this purpose push the ISOFIX release button (15), and the system will release the cover, which must be removed (fig. A.3a, A.3b).
- Place the seat without the cover (19) with the folded-out support leg on the vehicle seat.
- Attach the ISOFIX guides (18) to the car seat connectors (A.4).
- Slide the ISOFIX attachments (16) to their maximum length by unlocking and holding the sliding lever (12) (fig. A.5a) and then sliding the attachments (fig. A.5b). This has to be done on both sides of the seat.
- Connect the extended ISOFIX attachments (16) to the ISOFIX guides (18) installed in the car seat until a characteristic click occurs (fig. A.6). After the correct installation of the ISOFIX attachments, the indicator on the button (15) will change from red to green; verify the correct installation with green indicators (fig. A.7a, A.7b).

- ATTENTION! The locking clips are only correctly fastened when both button markers are completely green.
- When the seat is correctly installed with ISOFIX, position the seat facing forward. Push the seat rotation lever (7); (fig. A.9) to turn the seat in the direction of travel (fig. A.10b), a correctly locked position will be indicated by the green colour indicator at the seat rotation lever (7).
- Make sure the base is fixed by trying to pull it out of the ISOFIX attachment points.
- Push the base with a left-right movement towards the backrest of the vehicle seat until it is completely aligned with the backrest of the anti-rotation frame (14) (fig. A.8)
- When the seat is correctly installed with the ISOFIX attachments and the base's anti-rotation frame is fully seated against the backrest of the seat, proceed to adjust the support leg (9). ATTENTION: Before adjusting the support leg make sure the support leg extension indicator is green (8).
- Only after this has been done should the height of the support leg be adjusted.

- By holding down the leg height adjustment button (17), you will release the leg height lock and the leg should automatically extend. Adjust the leg height so that the foot meets resistance with the vehicle's ground; now you can release the button. If after the leg height lock the foot indicator (10) turns green, it means that the installation is correct (fig. A.13) otherwise repeat the adjustment of the support leg height.

**ATTENTION! Never mount the foot of the support leg on the glove box on the floor of the vehicle, there is a risk of the glove box collapsing during an accident, if in doubt consult the vehicle handbook.**

**ATTENTION: The support leg must never hang in the air and no objects may be placed under it.**

IMPORTANT: Make sure the support leg is supporting and not raising the bottom of the I- GUARD seat above the plane of the car seat.

- Take hold of the seat and check that it is securely fastened without slack. All ISOFIX attachments and support leg indicators should display green. If not, repeat the previous installation steps.

NOTE: Make sure the seat position is well established and stable. Check the indicators on the ISOFIX attachment and the support leg.

**B.1**

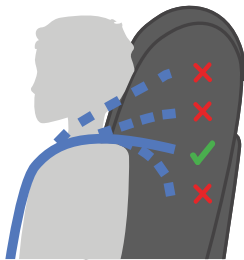

## **5.0 Height of headrest and shoulder straps**

To adjust the height of the headrest, proceed as follows:

- At the same time, while holding down the 5-point harness adjustment button (4), loosen the harness to allow for more freedom in adjusting the height of the headrest.
- Hold the head restraint adjustment lever (13) which is located at the back of the headrest. If you want to raise the headrest, pull the handle gently upwards. Adjust the headrest to the desired height. When the height has been adjusted, release the adjusting handle, and the headrest will be locked in the selected position.
- The height of the headrest can be lowered by pressing the height adjustment lever (13). When the height has been adjusted, release the adjusting handle, and the headrest will be locked in the selected position.

Adjust the height of the shoulder straps so that the strap enters the seat back flat, horizontally just above the child's shoulders. Make sure that the shoulder straps are correctly adjusted to the child's shoulders according to (fig. B.1).

NOTE: If necessary, repeat the adjustment of the headrest height until the shoulder straps are adjusted to the optimal height. Make sure that the harness is not twisted.

B.2a

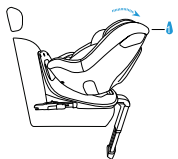

B.2b

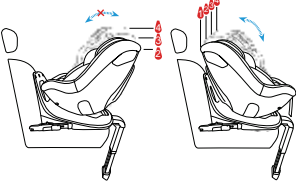

## 5.1 Rotating mechanism

- The rotation mechanism is a function which helps to position the child in the seat or to remove it in a comfortable way. Correct positioning of the seat in the direction of travel (fig. A.14):

A.14):

- a) from 40 to 105 cm rearward-facing,
- b) from 76 to 105 cm forward-facing.

- Turn the seat with the seat rotation lever (7), this function allows you to easily position and remove the child from the seat. Turn the seat, place the child in the seat, secure the child with the 5-point harness, and perform the rotation of the seat according to the above recommendation for each cm group. Verify that the rotation function is correctly locked. For this purpose check the colour of the indicator near the seat rotation lever (7) - the green colour confirms that the seat rotation function is locked (Fig. A.9).

## 5.2 Backrest adjustment / Backrest tilt adjustment

- The angle of the seat can be adjusted (fig. A.4) using the lever (6) under the seat. Pull the lever and move the seat. Release the lever at the desired position. Move the seat slightly until you hear a distinct clicking sound - the seat is now secured in the chosen position.

**NOTE: Between 40 and 105 cm with the seat rearward-facing, use position '1', the most reclined position of the seat (fig. B.2a). Between 76 and 105 cm with the seat installed forward-facing, you can use the full range of backrest recline adjustment in positions '1' to '4' (fig. B.2b).**

B.3

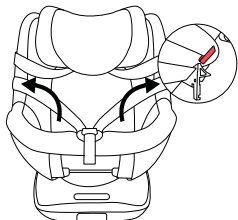

B.4

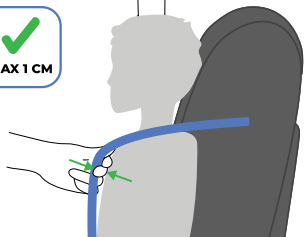

### 5.3 Securing the child with a 5-point seat harness

- Loosen the harness completely by pressing the button (4) and pulling the harness. Do not pull on the shoulder cushions.
- Release the buckle (3). Hook the 5-point harness on the harness holders (11), which are located at the sides of the seat (fig. B.3). Position your child in the seat.
- Adjust the headrest to the child's height (see section 5.0).
- Fold the two buckle clasps together to interlock and insert them into the buckle (3) until you hear a 'click'.

### 5.4 Tightening of 5-point safety harnesses

- Pull on the shoulder straps to eliminate any play in the hip area so the belt lies flat.
- Tighten the 5-point harnesses with the adjusting belt (5) until the harnesses lie flat on and close to the child's body. Ensure that the shoulder straps are snug against the child's shoulders. Proper tension is ensured when, in the space between the shoulder straps and the child's chest, a maximum of one finger (approx. 1 cm) can be inserted between the straps and the child's body (fig. B.4).

NOTE: The 5-point harnesses must be positioned as low as possible on the child's hips. Make sure the harness is not twisted.

## B.5



40-60 cm



+



## B.6



> 60-105 cm



## 5.5 Insert

A child insert not only improves comfort and gives extra support for very young children but also serves to protect the child. The insert must be used until your child is 60 cm tall (fig B.5).

When your child reaches a height of 60 cm, the insert must be removed (fig B.6).

Store the child insert in a safe place for future use. NOTE: Only use this original Kinderkraft I-GUARD insert. This insert is only intended for use with the I-GUARD seat.

## 5.6 Removing the seat (ISOFIX attachment system + support leg)

- To release the support leg support (9), press the support leg height adjustment button (17). Grasp the foot (10) and slide it back into the support leg.
- Press the release button (15) located on both ISOFIX attachments. The attachments will be released and the colour of the ISOFIX indicators (15) will change from green to red. Retract the ISOFIX attachments using the shift lever (12), slide them back into the seat base by exerting pressure on the attachments towards the seat, so that they engage in the seat base, do this on both sides of the seat.

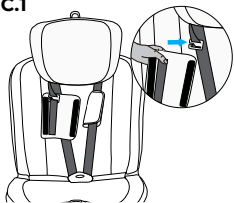
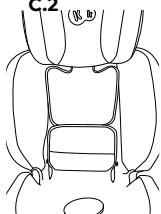
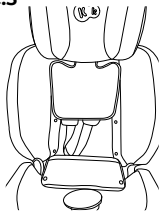
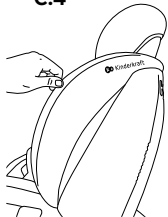
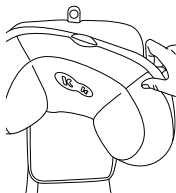

**C.1****C.2****C.3****C.4****C.5**

## 6.0 Removing/fitting the cover

- Removing the covers of the inner belts: undo the hook-and-loop fastener on the inside of the covers and remove the covers, which are hooked to the metal hooks (fig. C.1).
- Removing the back and the seat cover: detach the four tensioning fasteners securing the cover to the back part of the seat backrest (fig. C.2, C.3). Remove the cover from the side covers by sliding the fabric (fig. C.4).
- Gently pulling the fabric from both sides of the seat towards the outside of the seat, slide the cover off the front of the seat. Make sure that the fabric slides down around the belt adjustment button. The cover can now be removed from the seat by pulling it over the headrest.
- Removing the cover from the headrest: Grasp the upper part of the cover behind the headrest height adjustment button and gently slide the fabric off the upper part of the headrest (fig. C.5). Once the material on the upper part has been slid off, proceed to the removal of the cover on the sides of the headrest. To install the cover, proceed in the reverse order.

## 6.1 Cleaning

Only use the original cover as it is an important part of the safety of the seat.

CAUTION: Do not use the seat without the cover. Make sure you check and clean the seat regularly.

- The cover can be removed and washed in mild powder on a delicate programme (30°C). Please observe the washing instructions on the cover label. The colours may fade if washed at temperatures above 30°C. Do not spin dry or tumble dry the cover (this may cause the fabric layers to separate). The cover should not be exposed to prolonged sunlight. In order to wash the headrest insert, it is recommended to remove the foam beforehand. There is a removable foam in an internal pocket of the headrest insert.
- Plastic parts can be cleaned with a mild detergent and warm water. Never use strong cleaning agents or bleach!
- Components such as the 5-point harness adjustment strap and the crotch belt buckle are components that should be checked regularly as they are prone to foreign bodies and can be cleaned with a soft cloth or sponge using warm water.

The full text of the Terms and Conditions of the Warranty is available on the website [WWW.KINDERKRAFT.COM](http://WWW.KINDERKRAFT.COM)



**(AR)** بضمان مصلحة عملائنا - نحن في خدمتكم! إذا كانت لديكم أي مشكلة مع المنتج الذي حصلتم عليه، فيجربى الاتصال بنا بالطريقة التي تفضلونها!

**(CS)** V zájmu péče o naše klienty - jsme rádi k dispozici! Pokud jste se setkali s nějakým problémem v souvislosti s obdrženým výrobkem, kontaktujte nás způsobem, který vám nejvíce vyhovuje!

**(DE)** In Sorge für unsere Kunden - stehen wir gerne zu Ihrer Verfügung! Wenn Sie auf ein Problem mit dem erhaltenen Produkt treffen, treten Sie bitte mit uns in Kontakt in der bequemsten Weise für Sie!

**(EN)** In the interests of our Clients - we are at your disposal! If you have a problem with the product you received, contact us in the most convenient way for you!

**(ES)** ¡Por el bien de nuestros clientes, estamos a su disposición! ¡Si tiene cualquier problema con el producto recibido, póngase en contacto con nosotros de forma más cómoda para usted!

**(FR)** Dans l'intérêt de nos clients - nous sommes à votre disposition! Si vous avez un problème avec le produit que vous avez reçu, contactez-nous de la manière la plus pratique pour vous!

**(HU)** Bármikor állunk az ügyfeleink rendelkezésére! Ha az átvett termékkel kapcsolatban valamilyen problémába ütközött, az Onnek legmegfelelőbb módon vegye fel velünk a kapcsolatot!

**(IT)** Prendersi cura dei nostri Clienti - siamo alla Vostra disposizione! Se hai incontrato un problema con il prodotto che hai ricevuto. Contattaci nel modo piu conveniente per te!

**(NL)** In het belang van onze klanten - staan wij ter beschikking! Als u een probleem met het ontvangen product tegenkomt, neemt contact met ons op via de manier die u het makkelijkste vindt!

**(PL)** W trosce o naszych Klientów - jesteśmy do dyspozycji! Jeśli napotkałeś problem dotyczący otrzymanego produktu, skontaktuj się z nami w najbardziej dogodny dla Ciebie sposób!

**(PT)** Para o conforto dos nossos Clientes - estamos sempre à sua disposição! Se tiver qualquer problema com o nosso produto, entre em contacto conosco de modo mais confortável para si!

**(RO)** In interesul clienților noștri - suntem la dispoziția dumneavoastră! Dacă aveți o problema cu produsul pe care l-ați primit, contactați-ne în modul cel mai convenabil pentru dvs.!

**(RU)** заботясь о наших клиентах, мы находимся в вашем распоряжении. Если вы столкнулись с проблемой, связанной с полученными продукто, свяжитесь с нами наиболее удобным для вас способом!

**(SK)** Náš zákazník je pre nás dôležitý - sme vám k dispozícii! Ak máte akýkoľvek problém súvisiaci s doručeným produktom, kontaktujte nás spôsobom, ktorý vám najviac vyhovuje!

**(SV)** I våra kundens intresse - vi står till ditt förfogande! Om du har problem med den produkt du fick, kontakta oss på det mest praktiska sättet för dig!

### International contact:

support@kinderkraft.com  
(0048) 61 646 02 37



kinderkraftofficial



kinderkraft



kinderkraftofficial

منتج/ VÝROBCE/HERSTELLER/MANUFACTURER/FABRICANTE/FABRICANT/  
GYARTÓ/FABBRICANTE/FABRIKANT/PRODUCTENT/FABRICANTE/PRODUCĂTOR/  
ПРОИЗВОДИТЕЛЬ/VÝROBCA/TILLVERKARE:

**4Kraft Sp. z o.o. ul. Tatrzanska 1/5**  
**19 60-413 Poznań, Poland**