



# ASSEMBLY INSTRUCTIONS

**MODEL : 097-000006**

**IMPORTANT NOTE :**

- \* PLACE ALL WOODEN PARTS ON A CLEAN AND SMOOTH SURFACE SUCH AS A RUG OR CARPET TO AVOID THE PARTS FROM BEING SCRATCHED.
- \* BEFORE YOU BEGIN, KINDLY FOLLOW THE ASSEMBLY INSTRUCTIONS STEP BY STEP.

HARDWARE LIST			
A	JCBB M8 x 80mm + S/W 5/16" + F/W 5/16" x 22mm		8PCS
B	ALLEN KEY M5		1PC

PART LIST		
1	TABLE TOP	1PC
2	TABLE LEG	4PCS

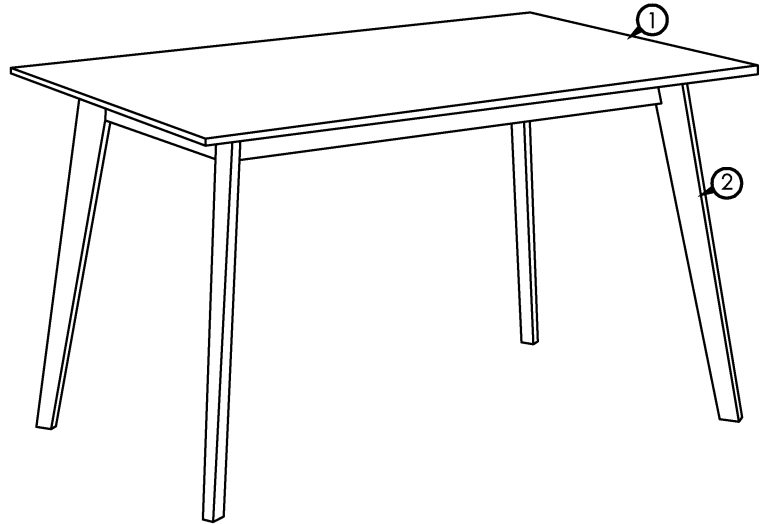

COMPLETED TABLE ASSEMBLY.

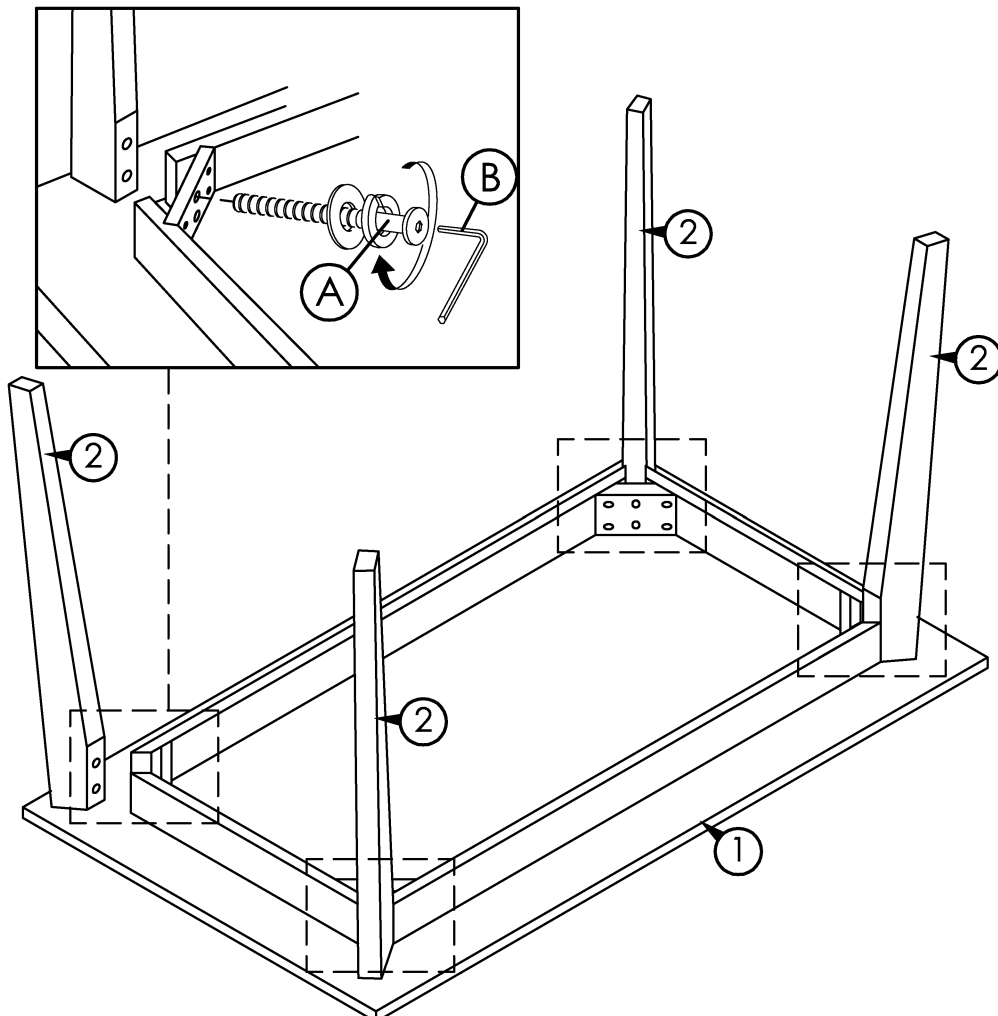

# ASSEMBLY INSTRUCTIONS

**MODEL : 097-000012**

**IMPORTANT NOTE :**

- \* PLACE ALL WOODEN PARTS ON A CLEAN AND SMOOTH SURFACE SUCH AS A RUG OR CARPET TO AVOID THE PARTS FROM BEING SCRATCHED.
- \* BEFORE YOU BEGIN, KINDLY FOLLOW THE ASSEMBLY INSTRUCTIONS STEP BY STEP.
- \* DO NOT TIGHTEN ALL SCREWS UNTIL THE CHAIR IS FULLY SET-UP.

HARDWARE LIST		PART LIST		
A	JCBC M6 x 25mm + S/W M6 + F/W M6 x 13mm	1	LEG L/R	2PCS
		4PCS	2	TOP REST
B	JCBC M6 x 55mm + S/W M6 + F/W M6 x 13mm	3	CHUSION SEAT	1PC
		4PCS	4	CORNER BLOCK (LONG)
C	JCBC W SCREW M7 x 40mm	5	CORNER BLOCK (SHORT)	2PCS
D	FH SCREW #8 x 25mm			
E	ALLEN KEY M4			

**CAUTIONS :**

(1) **DO NOT FULLY-TIGHTEN THE NUT OR NUT BOLTS INITIALLY UNTIL ALL NUTS OR BOLT IS READY ASSEMBLED.**

(TO AVOID CAUSING DAMAGES TO THE THREAD, DO NOT OVER-TIGHTEN THE NUTS OR BOLTS.)

(2) **KEEP ALL HARDWARE PART OUT OF REACH OF CHILDREN.**

