

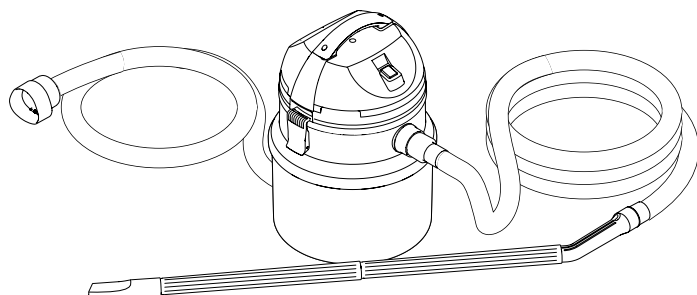

DE	Gebrauchsanleitung
EN	Operating instructions
FR	Notice d'emploi
NL	Gebruiksaanwijzing
ES	Instrucciones de uso
PT	Instruções de uso
IT	Istruzioni d'uso
DA	Brugsanvisning
NO	Bruksanvisning
SV	Bruksanvisning
FI	Käyttöohje
HU	Használati útmutató
PL	Instrukcja użytkowania
CS	Návod k použití
SK	Návod na použitie
SL	Navodila za uporabo
HR	Uputa o upotrebi
RO	Instrucțiuni de folosință
BG	Упътване за употреба
UK	Посібник з експлуатації
RU	Руководство по эксплуатации

PondoMatic

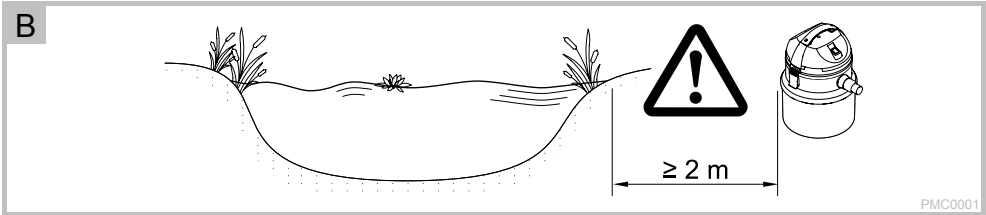

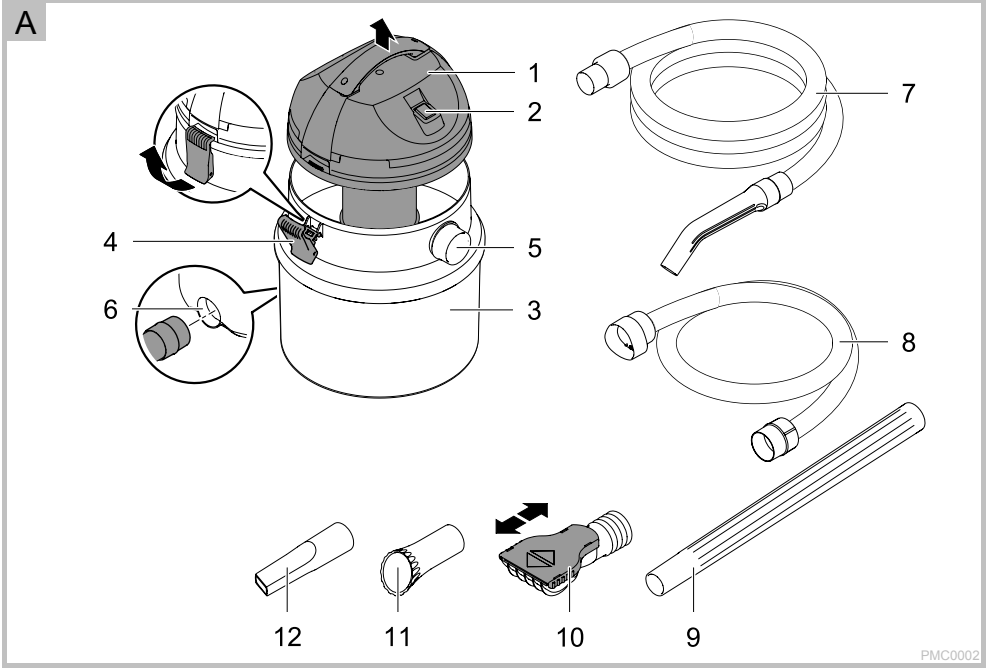

C

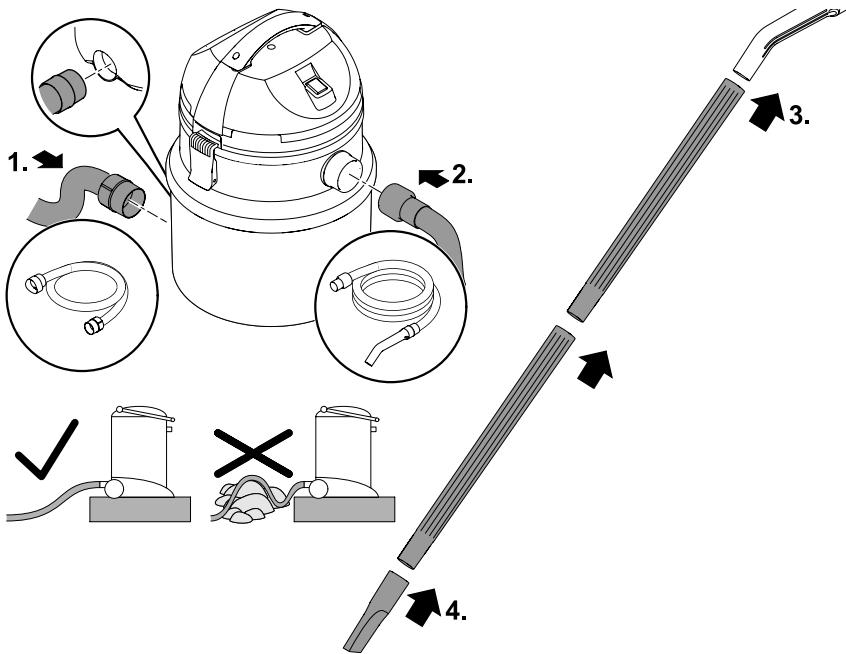

PMC0003



D

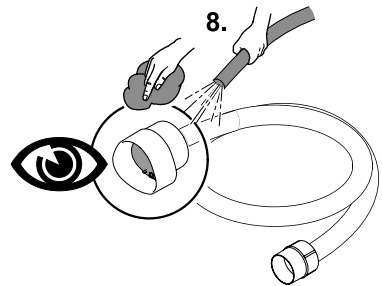
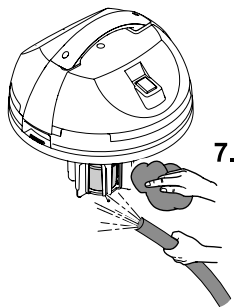
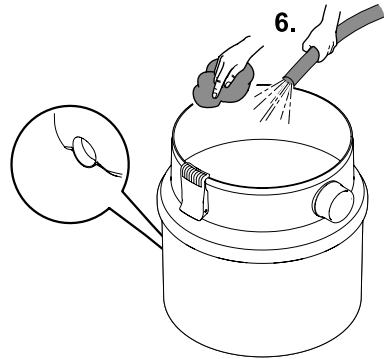
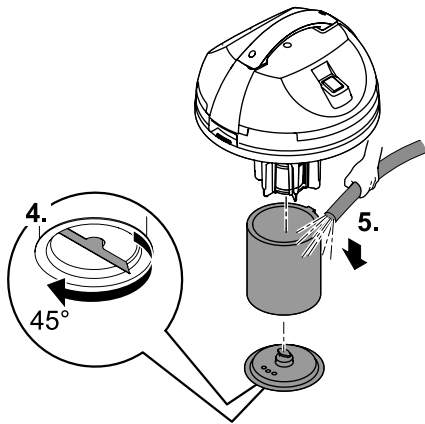
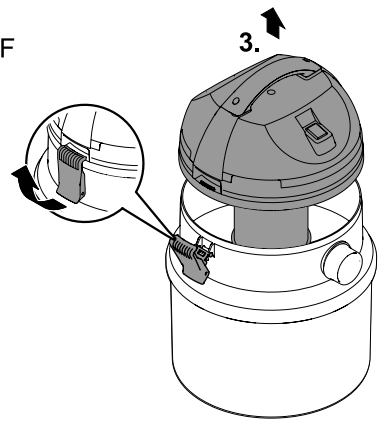
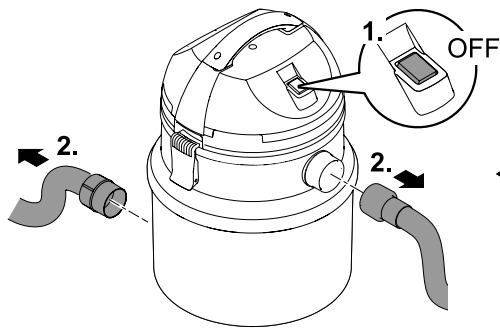

PMC0004

Translation of the original Operating Instructions

Information about these operating instructions

You made a good choice with the purchase of this product **PondoMatic**.
 Prior to commissioning the unit, please read the instructions of use carefully and fully familiarise yourself with the unit. Ensure that all work on and with this unit is only carried out in accordance with these instructions. Adhere to the safety information for the correct and safe use of the unit. Keep these instructions in a safe place! Please also hand over the instructions when passing the unit on to a new owner.

Symbols used in these instructions

The symbols used in this operating manual have the following meanings:



Risk of injury to persons due to dangerous electrical voltage

This symbol indicates an imminent danger, which can lead to death or severe injuries if the appropriate measures are not taken.



Risk of personal injury caused by a general source of danger

This symbol indicates an imminent danger, which can lead to death or severe injuries if the appropriate measures are not taken.



Important information for trouble-free operation.

A Reference to one or more figures. In this example: Reference to Fig. A.

→ Reference to another section.

Product Description

Delivery scope and unit configuration

The parts included in the scope of delivery are inside the container and have to be removed first!

How to proceed:

A

1. Undo the side locking clips and remove the motor housing.
2. Take all loose parts out of the container.
3. Replace the motor housing and close the locking clips.

<input type="checkbox"/> A	PondoMatic	Quantity
1	Motor housing	1
2	ON/OFF switch	1
3	Container	1
4	Locking clip	2
5	Inlet, suction hose connection	1
6	Outlet, drain hose connection	1
7	Suction hose	1
8	Drain hose	1
9	Extension tube	2
10	Adjustable universal nozzle – Nozzle fully open (10 mm): Suitable for pond liner, no pebbles at the bottom of the pond, thick layer of sludge – Nozzle closed (2 mm): Suitable for pond liner, layer of pebbles at the bottom of the pond, thick layer of sludge	1
11	Algae nozzle	1
12	Crevice nozzle	1

Function description

PondoMatic is a special pond vacuum for removing sludge from ponds and pools.

- High performance vacuum with 1400 watt motor.
- Switches over automatically between suction and emptying mode.
- The delivery scope includes:
 - Crevice nozzle, algae nozzle and universal nozzle (adjustable from 2 to 10 mm).
 - 4 m suction hose and 2 m drain hose

Intended use

PondoMatic, referred to in the following as "unit", may only be used as specified in the following:

- For pond sludge removal.
- Operation under observance of the technical data.

The following restrictions apply to the unit:

Never use the unit to collect flammable or toxic substances

- (e.g. benzene, asbestos, asbestos dust, copier toner),
- volatile substances,
- acids,
- hot or glowing ash,
- dust, sand or similar dirt.

Safety information

Hazards to persons and assets may emanate from this unit if it is used in an improper manner or not in accordance with its intended use, or if the safety instructions are ignored.

This unit can be used by children from the age of 8 and by persons with physical, sensory or mental impairments or lack of experience and knowledge, as long as they are supervised or instructed on how to use the unit safely and are able to understand the potential hazards. Do not allow children to play with the unit. Do not allow children to clean or maintain the unit without close supervision.

Hazards encountered by the combination of water and electricity

- The combination of water and electricity can lead to death or severe injury from electrocution, if the unit is incorrectly connected or misused.
- Prior to reaching into the water, always switch off the mains voltage to all units used in the water.

Correct electrical installation

- Electrical installations must meet the national regulations and may only be carried out by a qualified electrician.
- A person is regarded as a qualified electrician, if, due to his/her vocational education, knowledge and experience, he or she is capable of and authorised to judge and carry out the work commissioned to him/her. This also includes the recognition of possible hazards and the adherence to the pertinent regional and national standards, rules and regulations.
- For your own safety, please consult a qualified electrician.
- The unit may only be connected when the electrical data of the unit and the power supply coincide. The unit data is to be found on the unit type plate or on the packaging, or in this manual.
- Ensure that the unit is fused for a rated fault current of max. 30 mA by means of a fault current protection device.
- Extension cables and power distributors (e. g. outlet strips) must be suitable for outdoor use.
- Minimum safety distance between the unit and the water: 2 m.
- Ensure that the power connection cable cross section is not smaller than that of the rubber sheath with the identification H05RN-F. Extension cables must meet DIN VDE 0620.
- Protect the plug connections from moisture.
- Only plug the unit into a correctly fitted socket.

Safe operation

- Never operate the unit if either the electrical cables or the housing are defective!
- Do not carry or pull the unit by its electrical cable.
- Route cords/hoses/lines in a way that they are protected against damage, and ensure that they do not present a tripping obstacle.
- Only open the unit housing or its attendant components, when this is explicitly required in the operating instructions.
- Only execute work on the unit that is described in this manual. If problems cannot be overcome, please contact an authorised customer service point or, when in doubt, the manufacturer.
- Only use original spare parts and accessories for the unit.
- Never carry out technical modifications to the unit.
- The power connection cables cannot be replaced. When the cable is damaged, the unit or the component needs to be disposed of.
- Only operate the unit if no persons are in the water!
- The unit, the connections and plugs are not water-proof and must not be routed or installed in water.
- Keep the socket and power plug dry.

Operation

Set-up the unit

B

- Place the unit at least 2 m from the pond and above the water level.
- Place the unit on level ground so that it is securely positioned and cannot tip over.

Connect the unit

How to proceed:

C

1. Attach the drain hose to the outlet fitting on the container.
 - Route the drain hose with an incline to ensure that the extracted water can drain via gravity.
2. Attach the suction hose to the inlet fitting on the container.
3. Fit the extension tubes to the suction hose.
4. Fit the desired nozzle to the end of the extension tube.
 - Adjust the universal nozzle to the pond floor conditions. (→ Delivery scope and unit configuration)

Use as sludge remover



Note!

- Only use the unit with a filter!
- The operating modes "suction" and "emptying" each last approx. 25 seconds. The unit switches over automatically between the modes. Sequence: The unit is in suction mode. The unit is switched off. The stop valve at the outlet opens and the dirty water runs out. The unit is switched on again.

How to proceed:

1. Connect the unit to the power supply and switch on.
2. Guide the universal nozzle to the floor of the pond.
3. Move the nozzle with slow and uniform movements to vacuum up the sludge.
 - Turn the floor nozzle through 180° to vacuum up thin layers of sludge or to clean rigid preformed pond liners.
4. Switch off the unit after use.

Remedy of faults

Malfunction	Cause	Remedy
The unit does not perform its suction function	Drain hose incorrectly fitted	The non-return valve must be located at the free end of the drain hose
	Excessive height difference between water level and unit	Places the unit at water level height
The unit does not reach its full capacity	Dirt has accumulated in the foam filter, in the suction tube or in the suction hose	Remove soiling
	Dirt has accumulated in the area of the non-return valve at the drain hose preventing it from closing properly	Remove soiling
The collection container does not run empty, the unit does not prime	The collection container cannot drain	Lay the drain hose without kinks. Provide slight gravity for the drain hose. After draining, almost no water should remain in the collection container.
	Collection container and drain hose are soiled	Remove soiling
Low suction capacity	The more tubes are used, the higher the tube frictional resistance. The suction capacity reduces.	Hold the suction hose as flat as possible to improve the suction performance

Wear parts

Filters and valve rubber elements are wear parts and are not covered by our warranty.

Maintenance and cleaning

How to proceed:

D

1. Switch off the unit and disconnect the power plug.
2. Disconnect the hoses.
3. Undo the side locking clips and remove the motor housing.
4. Undo the filter holder.
5. Remove the filter and rinse under running water.
 - If the filter is damaged, replace it with an original filter.
6. Clean the container.
7. Clean the bottom of the motor housing.
8. Check the rubber valve in the drain hose and clean.
9. Reassemble the unit in the reverse order.

Storage/Over-wintering

Storage

Empty out the collection container and clean the unit. Store in a dry, frost protected room, inaccessible to children.

Disposal



Do not dispose of this unit with domestic waste! For disposal purposes, please use the return system provided. Disable the unit beforehand by cutting off the cables.

Guarantee conditions

PfG grants a 2 year guarantee from the date of sale on proven material and manufacturing faults. Prerequisite for our guarantee is the presentation of the purchase receipt. Our guarantee will become null and void if the unit is misused, electrically or mechanically damaged by inappropriate use and improper repair by non-authorized workshops. Repairs are reserved for workshops authorised by PfG or by PfG itself. In the case of warranty claims, please return the defective unit or part freight paid to PfG together with a description of the fault and the purchase receipt. PfG reserves the right to invoice repair costs. PfG is not liable for transport damage. Any damage must be claimed against the carrier. Further claims of whatever type, especially consequential damage, are excluded. This guarantee does not affect the final customer's claims against the dealer.

DE	Abmessungen	Gewicht	Bemessungsspannung	Leistungsaufnahme	Saugschlauch	Ablaufschlauch	Kabellänge	Wassertemperatur
EN	Dimensions	Weight	Rated voltage	Power consumption	Suction hose	Draining hose	Cable length	Water temperature
FR	Dimensions	Poids	Tension de mesure	Consommation	Tuyau flexible d'aspiration	Tuyau d'écoulement	Longueur de câble	Température de l'eau
NL	Afmetingen	Gewicht	Dimensioneringsspanning	Stroomverbruik	Zuigslang	Afvoerslang	Kabellengte	Watttemperatuur
ES	Dimensiones	Peso	Tensión asignada	Consumo de potencia	Tubo flexible de aspiración	Tubo flexible de descarga	Longitud del cable	Temperatura del agua
PT	Dimensões	Peso	Voltagem considerada	Consumo de potência	Mangueira de sucção	Mangueira de descarga	Comprimento do cabo	Temperatura da água
IT	Dimensioni	Peso	Tensione di taratura	Potenza assorbita	Tubo flessibile di aspirazione	Tubo flessibile di scarico	Lunghezza cavo	Temperatura dell'acqua
DA	Dimensioner	Vægt	Nominal spending	Strømforsbrug	Sugeslange	Afløbsslange	Ledningslængde	Vandtemperaturen
NO	Mål	Vekt	Merkespenning	Inngangseffekt	Sugeslange	Avløpslange	Kabellengde	Vanntemperatur
SV	Mått	Vikt	övre märkspänning	Effekt	Sugslang	Utløpslang	Kabellängd	Vatttemperatur
FI	Mittit	Paino	mittitajuttamite	Ottoteho	Imuletku	Laskuletku	Kaapelin pituus	Veden lämpötila
HU	Méreték	Súly	mért feszültség	Teljesítményfelvétel	Szivómlő	Leeresztő mlő	Kábelhossz	Víz hőmérséklet
PL	Wymiary	Ciezar	napięcie znamionowe	Pobór mocy	Wąż ssący	Wąż odpływowy	Diugość kabla	Temperatura wody
CS	Rozměry	Hmotnost	domezovací napětí	Příkon	Sací hadice	Odtoková hadice	Délka kabelu	Teplota vody
SK	Rozmery	Hmotnosť	dimenzionálne napätie	Prikon	Sacia hadica	Odtoková hadica	Dĺžka kábla	Teplota vody
SL	Dimenzije	Teža	dimenzionirana napetost	Nazivna moč	Sesalna cev	Odvodna cev	Dožljina kabela	Temperatura vode
HR	Dimenzije	Masa	gornji nazivni napon	Prijemna snaga	Uisino crijevo	Odvodno crijevo	Dujljina kabela	Temperatura vode
RO	Dimensiuni	Masa	tensiunea măsurată	Putele consumată	Furtun de aspirare	Furtun de deversare	Lungime cablu	Temperatura apei
BG	Размери	Тегло	номинално напрежение	Консумирана мощност	Всмукателен марлуч	Изпускателен марлуч	Дължина на кабелите	Температура на водата
UK	Розміри	Вага	розрахункова напруга	Споживана потужність	Всмоктувальний шланг	Стічний шланг	Довжина кабелю	Температура води
RU	Размеры	Вес	расчетное напряжение	Потребляемая мощность	Всасывающий шланг	Сливной шланг	Длина кабеля	Температура воды
	370 x 370 x 540 mm	9.0 kg	~ 230 V / 50 Hz	1400 W	4 m	2 m	4 m	+4 ... +35 °C

			
DE	Schutz gegen das Eindringen von Spritzwasser	Nicht mit normalem Hausmüll entsorgen!	Achtung! Lesen Sie die Gebrauchsanleitung
EN	Protection against the ingress of splash water	Do not dispose of together with household waste!	Attention! Read the operating instructions
FR	Protection contre la pénétration de projection d'eau	Ne pas recycler dans les ordures ménagères !	Attention ! Lire la notice d'emploi
NL	Beveiliging tegen het binnendringen van spatwater	Niet bij het normale huisvuil doen!	Let op! Lees de gebruiksaanwijzing
ES	Protección contra la entrada de agua salpicante	¡No deseche el equipo en la basura doméstica!	¡Atención! Lea las instrucciones de uso
PT	Protecção contra respingos de água	Não deitar ao lixo doméstico!	Atenção! Leia as instruções de utilização
IT	Protezione contro la penetrazione di spruzzi d'acqua	Non smaltire con normali rifiuti domestici!	Attenzione! Leggete le istruzioni d'uso!
DA	Beskyttelse mod indtrængning af vandsprøjt	Må ikke bortskaffes med det almindelige husholdningsaffald!	OBS! Læs brugsanvisningen
NO	Beskyttelse mot inntrenging av vannsprut	Ikke kast i alminnelig husholdnings-savfall!	NB! Les bruksanvisningen
SV	Skydd mot inträngande stänkvatten	Får inte kastas i hushållssoporna!	Varning! Läs igenom bruksanvisningen
FI	Suoja roiskeveden sisäänpääsemisen estämiseksi	Älä hävität laitetta tavallisen talousjätteen kanssa!	Huomio! Lue käyttöohje
HU	Permetíviz behatolása elleni védelem	A készülékét nem a normál háztartási szeméttel együtt kell megsemmisíteni!	Figyelem! Olvassa el a használati útmutatót
PL	Zabezpieczenie przed wniknięciem pryskającej wody.	Nie wyrzucać wraz ze śmieciami domowymi!	Uwaga! Przeczytać instrukcję użytkowania!
CS	Ochrana proti pronikání odstříkující vody	Nelikvidovat v normálním komunálním odpadu!	Pozor! Přečtěte Návod k použití!
SK	Ochrana proti prenikaniu odstrekujúcej vody	Nelikvidovať v normálnom komunálnom odpade!	Pozor! Prečítajte si Návod na použitie
SL	Zaščita proti vdoru brizgov vode	Ne zavržite skupaj z gospodinjскими odpadki!	Pozor! Preberite navodila za uporabo!
HR	Zaštita protiv prodiranja prskajuće vode	Nemojte ga bacati u običan kućni otpad!	Pažnja! Pročitajte upute za upotrebu!
RO	Protecție împotriva pătrunderii apei prin stropire	Nu aruncați în gunoier maișjer !	Atenție ! Citiți instrucțiunile de utilizare !
BG	Защита срещу навлизане на пръски вода	Не изхвърляйте заедно с обикновения домакински боклук!	Внимание! Прочетете упътването
UK	Захист від потрапляння бризок води	Не викидайте разом із побутовим сміттям!	Увага! Читайте інструкцію.
RU	Защита от проникновения водяных брызг	Не утилизировать вместе с домашним мусором!	Внимание! Прочитайте инструкцию по использованию

Pos.	PondoMatic
1	28062
2	27741
3	27989
4	28063
5	27990
6	27834
7	33480
8	25389
9	27157
10	27303

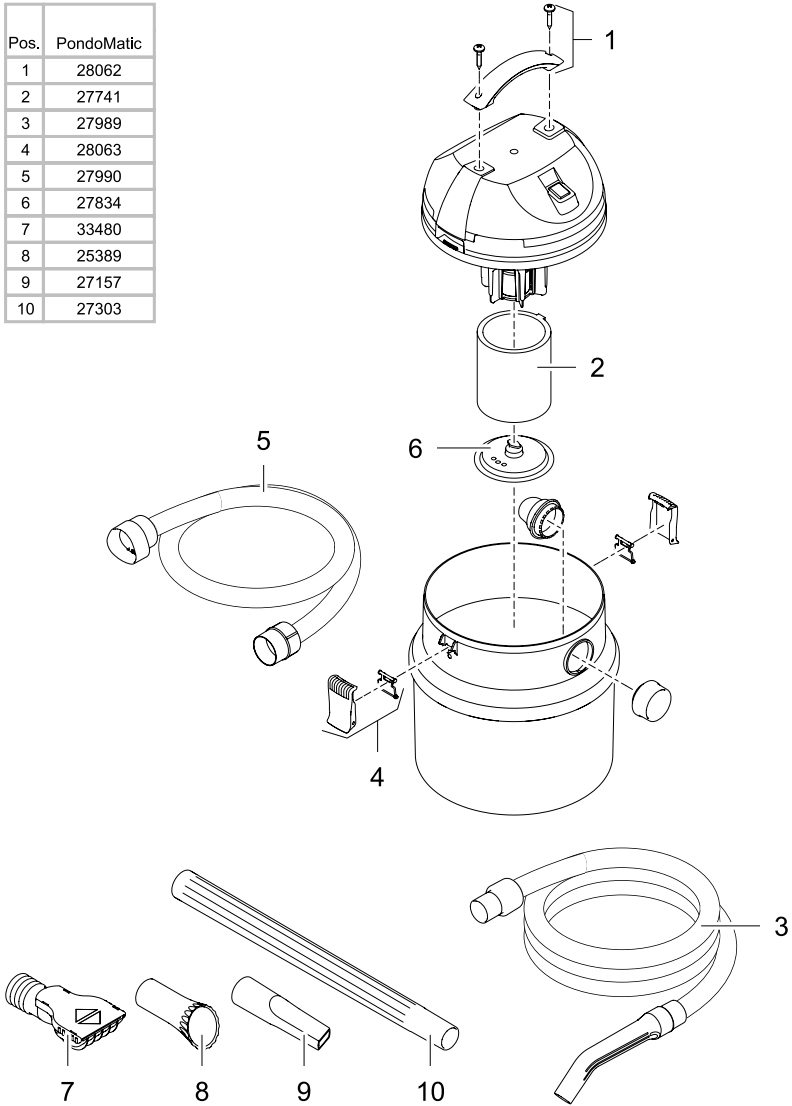

PMC0005